

CHAPTER - 3-2
PRINCIPLES OF ENERGY
CONSCIOUS DESIGN

Content:

- 3.1 Introduction
 - 3.2 Building Envelope
 - 3.3 Passive Heating
 - 3.4 Passive Cooling
 - 3.5 Daylighting
 - 3.6 Building Materials
 - References
-

3.1 INTRODUCTION

The energy conscious design approach helps designers and building owners to economically reduce building operating costs, while improving comfort for the building's occupants. The energy consumed by a building depends on its use (whether residential, commercial or industrial), the type of building (air-conditioned or otherwise), the interaction of spaces, and the climate. Architects have to ensure that the design of the built form suits the intended use of the building and the specific needs of the client within the framework of the prevailing climatic conditions.



That is, the parameters of architectural design are based on need, context and form, the relationships between which are outlined in Fig. 3.1. Appropriate combinations of these parameters lead to savings of energy required for maintaining healthy and comfortable indoor conditions.

In any building design, one employs simple techniques such as orientation, shading of windows, color, and vegetation among others, to create comfortable conditions. Such techniques pertain to the *building envelope*. Building envelopes not only provide the thermal divide between the indoor and outdoor environment, but also play an important role in determining how effectively the building can utilize natural lighting, ventilation, and heating and cooling resources. Thus, intelligent configuration and molding of the built form and its surroundings can considerably minimize the level of discomfort inside a building, and reduce the consumption of energy required to maintain comfortable conditions.

Yet, in extreme climates, comfortable indoor conditions cannot be completely achieved by limiting oneself to simple techniques. For example, in a city like Ahmadabad where the ambient temperatures can reach up to 42 °C in summer, simple techniques such as orientation, shading, color of external surfaces and insulation may help to bring down the temperature to around 36 °C [1]. A significant reduction no doubt, but the room temperature is still very much above comfort levels.



In such circumstances, additional features need to be considered. One way is to use passive techniques such as wind towers coupled with evaporative cooling to cause further cooling of the interiors.

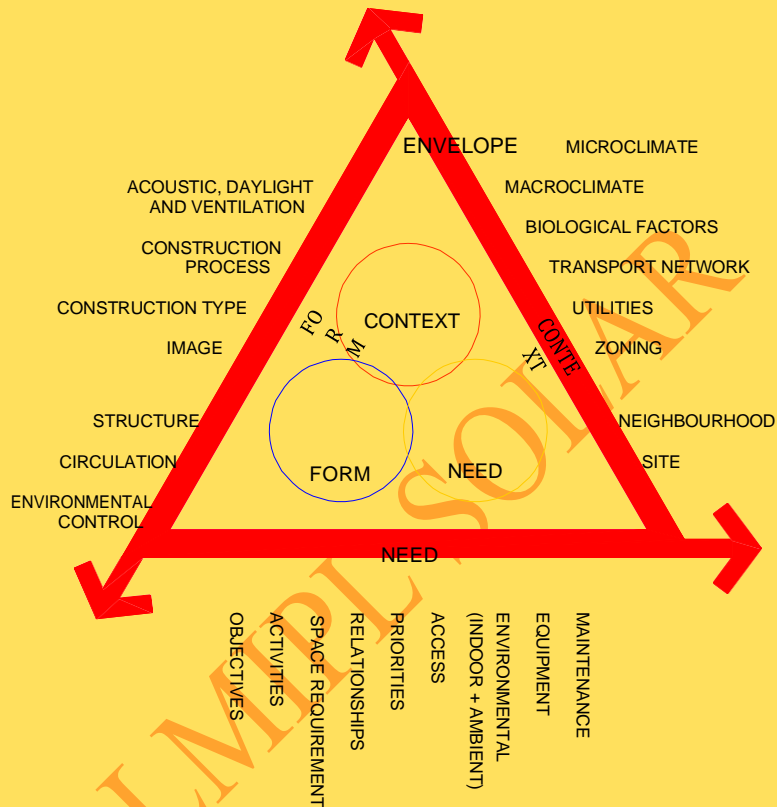

Fig. 3.1 Parameters of architectural design



Passive solar techniques involve methods of collecting, storing, distributing and controlling thermal energy flow by means of natural principles of heat transfer. Passive systems have no separate devices for collecting and storing energy, nor any mechanical means for transporting heat. Instead, they make use of the energy available in the immediate environment and effect energy exchanges through natural processes. However, the term 'natural energy flow' is certainly not synonymous with 'unregulated energy flow'. In fact, the natural flow can be reasonably regulated by controls such as dampers, openable windows, movable insulation or shading devices. Passive systems offer a number of advantages that afford large savings of energy; they are also easy to incorporate into buildings at little or no additional cost. Further, the simplicity of design, operation and maintenance invite interest. Common materials can be used in constructions and the systems subsequently maintained by laypersons. However, as passive systems are dependent on natural forces, it would be incorrect to compare their performance with that of air-conditioning systems.

4th Floor 4B, Mandira Apartments,
North Boag Road, T-Nagar Chennai- 600 017
Email: Solarbazaarpl@gmail.com
Web: www.almipl.com
Mobile: 94452 30332 / 9383132332

Green Energy Promoters



When rooms are required to be maintained at constant temperature and humidity, it is still advisable to use conventional systems.

This chapter elaborates on both, the simple techniques pertaining to building envelope as well as passive solar techniques. Wherever possible, the principles are accompanied by details of construction. An architect may use the methods described as a starting point for generating customized solutions. Techniques relevant to Indian conditions such as direct gain, Trombe wall, ventilation, evaporative cooling, and earth-air-pipe system are explained in greater detail than others.

The artificial is lighting load on a building can be significantly reduced if its design allows for effective daylighting. Additionally, building materials also play an important role in energy conscious architecture. This chapter also describes daylighting as a passive solar technique, and concludes with a discussion on alternative building materials and their embodied energy aspects.



The artificial is lighting load on a building can be significantly reduced if its design allows for effective daylighting. Additionally, building materials also play an important role in energy conscious architecture. This chapter also describes daylighting as a passive solar technique, and concludes with a discussion on alternative building materials and their embodied energy aspects.

3.2 BUILDING ENVELOPE

A building interacts with the environment through its external façades such as walls, windows, projections, and roofs, referred to as the building envelope. The envelope acts as a thermal shell, which if thoughtlessly constructed, would result in energy leaks through every component. Hence, each component needs to be properly chosen to ensure an energy efficient building. The choice depends on the site and the primary objective is, therefore, to examine the site conditions. Besides, an ideal orientation of the building at a site and proper building configuration play a significant role in the building's performance.



3.2.1 Site

Of the various factors influencing the building design, site conditions occupy an important position. The environmental conditions experienced on the site are due to the macroclimate as well as the microclimate (discussed in chapter 2). Site-specific conditions such as land form, vegetation, waterbodies, open spaces, etc. (section 2.6) play an important role in building design. Proper analysis of these conditions can enable one to choose a site and make suitable design plans. This would help save energy and also provide a fairly satisfactory indoor environment throughout the year.

3.2.1 Orientation

Appropriate orientation of buildings can provide physically and psychologically comfortable conditions in the building. It can help exclude the undesirable effects of severe weather to a great extent. For example, in cold climates, a building must be oriented to receive maximum solar radiation into the living areas for warmth on one hand, while keeping out the prevailing cold winds on the other. Conversely, in hot regions,



solar radiation and hot, dusty winds need to be avoided in summer, while cool winds must be admitted.

Thus, appropriate orientation can control the amount of solar radiation and wind entering a building.

The best orientation requires that the building as a whole should receive maximum solar radiation in winter and minimum in summer. To decide on an optimum orientation, it is essential to have an idea of the sun's position on a daily as well as seasonal basis by using tools such as the sun path diagram (Chapter 2, Fig. 2.1 b). It is also necessary to know the intensity of solar radiation on various external surfaces of the building as well as the duration of sunshine. Such information is available in various handbooks (Refer to Chapter 2). Once the orientation is decided, the heat entering a building can be controlled by (1) area and type of glazings, (2) types of walls and roofs, and (3) shading.

As mentioned, wind may be desirable or unwanted, depending on the climate. Hence, it is necessary to study the velocity and direction of the wind on an hourly and monthly basis. This helps one to identify the duration for which the wind may be desirable. Besides, the prevalent wind direction can be identified to plan the orientation of apertures for achieving the desired indoor air motion.



It is generally found that a variation of orientation of apertures upto 30° with respect to the prevalent wind direction, does not significantly affect the indoor ventilation (average indoor velocity) of the building [2]. upto 30° with respect to the prevalent wind direction, does not significantly affect the indoor ventilation (average indoor velocity) of the building [2].

Once orientation is fixed, wind can be controlled by:

- tilting and projecting surfaces to deflect wind
- providing openings of appropriate size providing windbreakers to reduce wind speed

To illustrate the effect of orientation, let us consider a rectangular conditioned building having fully glazed wall on one of its long sides. Let us also consider four orientations such as northwest-southeast, north-south, northeast-southwest and east-west of this building with respect to its long axis. The estimated annual cooling load of such a conditioned building in a few Indian cities is shown in Fig. 3.2. It is seen that in warm climates, the maximum load corresponds to the northwest-southeast orientation (the glass curtain wall facing southwest). Hence, such an orientation of the building should be avoided.



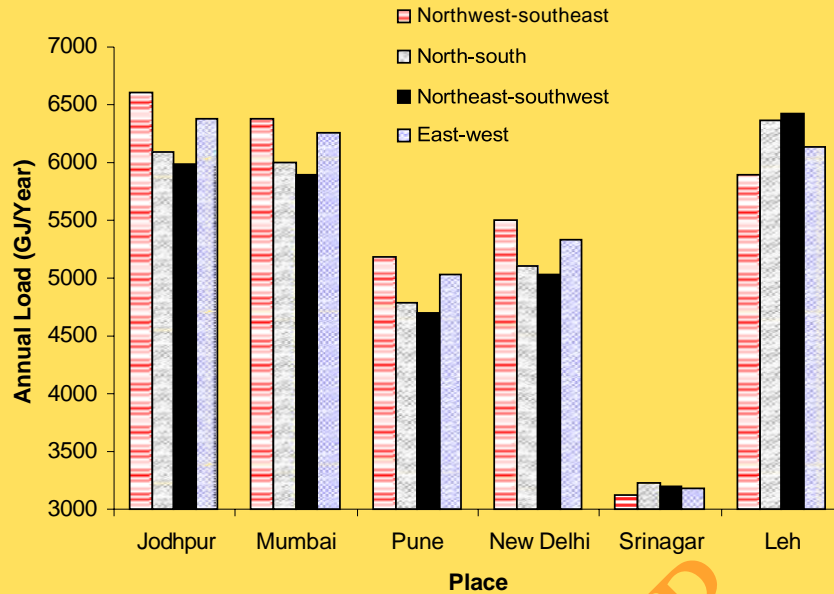

Fig. 3.2 Effect of orientation on the annual load of a conditioned building in various cities

3.2.2 Building configuration

Heat exchange between a building and its surroundings occurs primarily through the 'skin' of the building. Configuring the geometry of the building appropriate to the climate and usage can control the magnitude of the heat flow. For example, in an extremely cold climate, one needs to minimise heat loss from the building to the environment. This can be achieved by:

- a) using buffer spaces, e.g., sunspaces and balconies act as sitouts in favourable weather;



b) locating infrequently used spaces such as store rooms and toilets in the directions that face prevailing cold winds;

c) maximising exposure to solar radiation, e.g., major living rooms may be arranged facing the sun to gain heat;

d) locating habitable spaces appropriately, e.g., the most habitable spaces may be kept on leeward side to avoid cold winds. They may be clustered together to reduce exposure to cold.

The heat flow due to radiation and air movement can be controlled by varying the following aspects of the building configuration:

- **surface area to volume ratio (S/V ratio):** The ratio of the surface area to the volume of the building (S/V ratio) determines the magnitude of the heat transfer in and out of the building. The larger the S/V ratio, the greater the heat gain or loss for a given volume of space. Conversely, a smaller S/V ratio will result in the reduction of heat gain/loss. For example, in cold climates it is preferable to have compact house forms with minimum S/V ratio. Figure. 3.3 shows the surface to volume ratios for various building shapes.



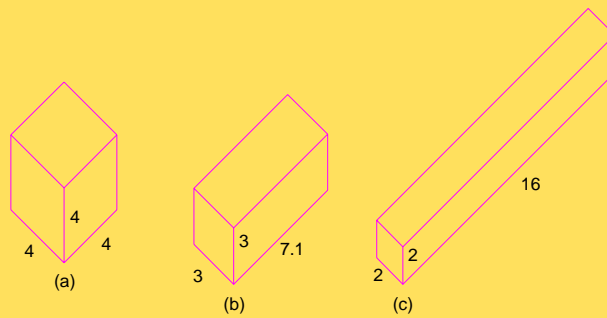

SOLID SHAPE	SURFACE AREA/ VOLUME		
	Surface Area 'S'	Volume 'V'	Ratio 'S/V'
a	96	64	1.5
b	103.2	64	1.61
c	136	64	2.13

Fig. 3.3 Surface area to volume ratio (S/V ratio) for a few building shapes

- **shape of the building:** Wind when obstructed by a building creates pressure differences, that is, positive pressure on the windward side and negative pressure on the leeward side. Consequently, a new airflow pattern is established around the building. Thus, wind pattern across a building can be modified by shaping it appropriately.
- **buffer spaces:** Buffer spaces such as courtyards, atria, balconies and verandahs provide shade and catch wind.



arrangement of openings: Appropriate openings connecting high and low pressure areas provide effective ventilation. Solid and glazed surfaces need to be suitably arranged and oriented for receiving or rejecting solar radiation.

shading: Shading of surfaces can be achieved by the self-shading profiles of buildings e.g. H-type or L-type as compared to the simple cube. Shading devices such as chajjas block the solar radiation incident on the exposed surfaces of a building, consequently reducing heat gain. It has been found that in a low-rise residential building in Ahmadabad, shading a window by a simple horizontal chajja of 0.76m depth can lower the maximum room temperature by upto 4.6 °C [3]. Therefore, the shading of windows can significantly improve the performance of the building. In the case of hot and dry regions, taller structures may be placed towards the south, so as to shade other structures in a cluster. Walls can be shaded by the use of projections, balconies, fins, textured paints and vegetation. Openings can be shaded with appropriately sized chajjas, fins and awnings externally (Fig. 3.4), and/or by using openable shutters and movable covers like curtains and venetian blinds internally. Translucent materials like heat absorbing or heat reflecting glass, plastics, painted glass, etc. can also be used for reducing solar heat gains through glasses.



The effectiveness of these shading devices are evaluated in terms of shade factors (defined as the ratio of the solar heat gain from the fenestration under consideration, to the solar heat gain through a 3 mm plain glass sheet). Table 3.1 presents the measured values of shade factors for various types of shading devices; the corresponding U-values are also mentioned [4,5].

Table 3.1 Transmittance and shade factors of different shading devices [5]

Name of the Shading Device	Transmittance (W/m ² -K)	Shade Factor
Plain glass sheet (3.0 mm thick)	5.23	1.00
Plain glass + wire mesh outside	5.00	0.65
Painted glass		
(i) White paint	5.22	0.35
(ii) Yellow paint	5.22	0.37
(iii) Green paint	5.22	0.40
Heat absorbing glass	4.65	0.45
Plain glass sheet + Venetian blind inside		
(i) Light colour	3.72	0.35
(ii) Dark colour	3.72	0.40
Plain glass sheet		
(i) 100 percent shaded	5.23	0.14
(ii) 75 percent shaded	5.23	0.34
(iii) 60 percent shaded	5.23	0.56

As the roof of a building receives the maximum radiation, shading it with movable canvas covers, plant cover (pergola) or a roof garden can reduce heat gain.



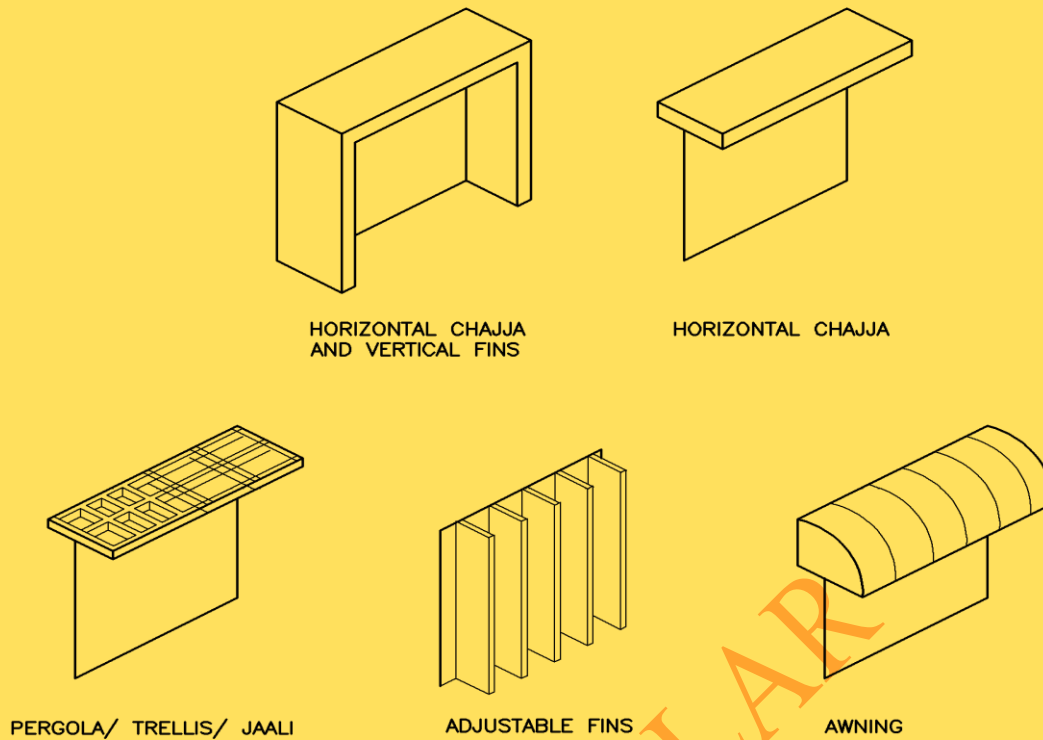
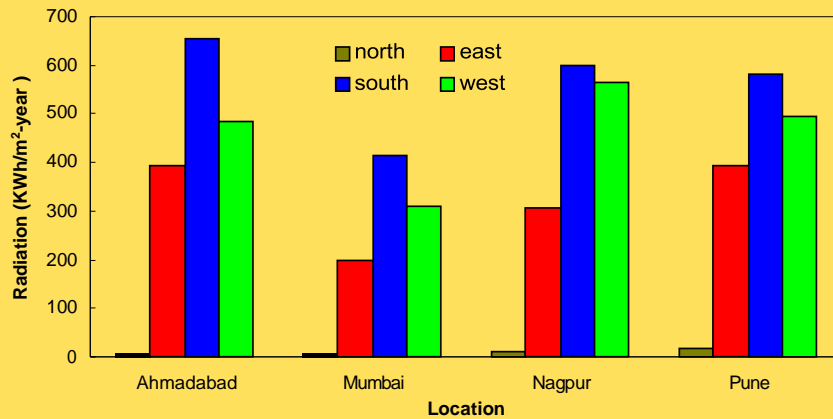

Fig. 3.4 Types of shading devices

The reduction in yearly beam radiation incident on a typical window of size 1.2m X 1.2m having different external shading devices (horizontal and vertical) in some cities of India is presented in Fig. 3.5 [3]. The figure shows that providing a horizontal chajja can reduce the incident beam radiation falling on the window in various orientations considerably. The shading can be further enhanced by providing vertical fins. The results for various shading devices (horizontal chajjas and vertical fins) on windows of different sizes and in various orientations is given in Appendix III.1 [3].





(a) Unshaded window (1.2m x 1.2 m)

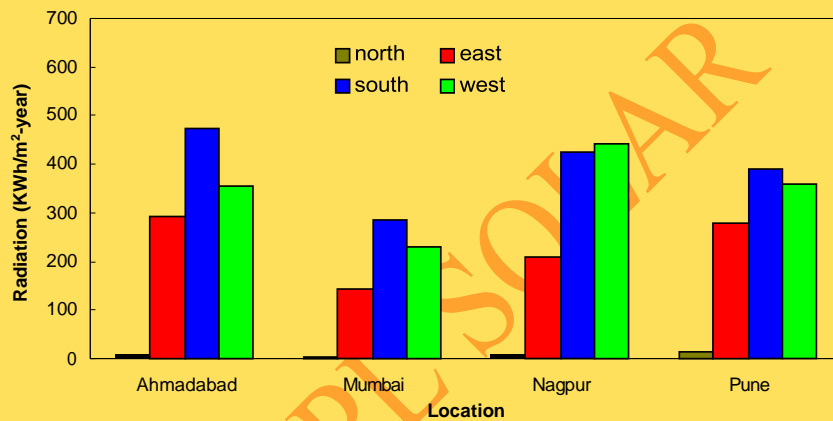

(b) Window shaded by 0.6 m chajja with 0.15 m extension (1.2m x 1.2 m)

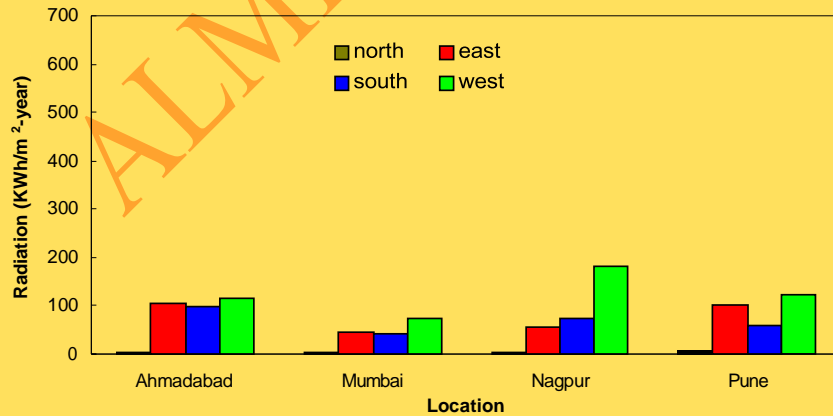

(c) Window shaded by 0.6 m chajja and full fins (1.2m x 1.2 m)

Fig. 3.5 Reduction in yearly beam radiation incident on windows due to shading [3]



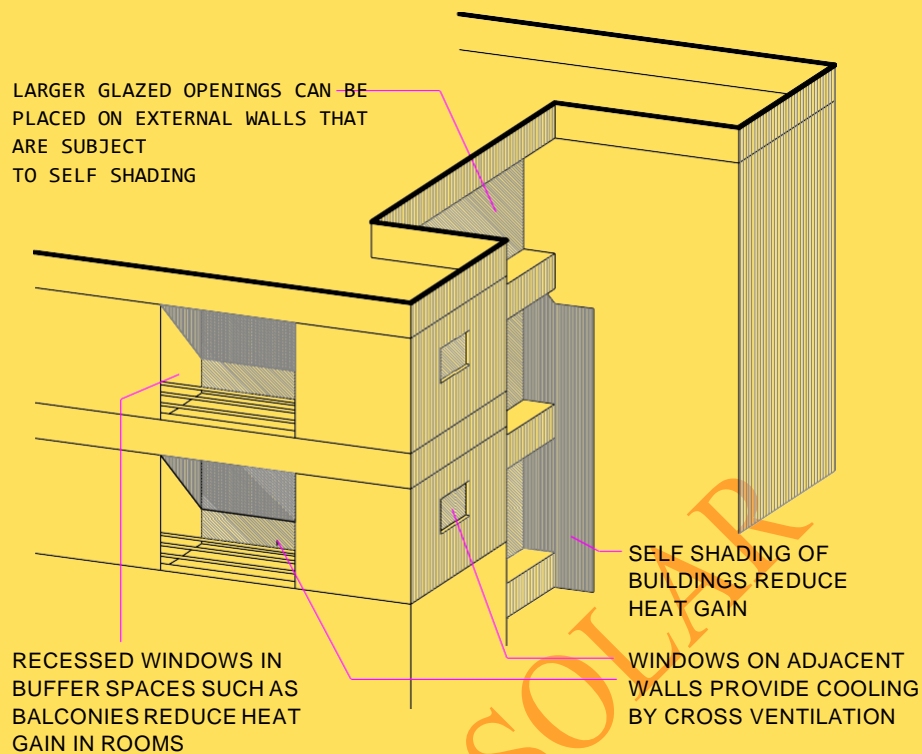

Fig. 3.6 Aspects of building configuration that can reduce heat gains in a hot climate

The physical manifestation of some of the concepts on building configuration that can reduce heat gain in a hot climate is depicted in Fig 3.6.

3.2.3 Building components

The nature of a building envelope determines the amount of radiation and wind that will enter the building.



It consists of the following elements:

- (A) Roof
- (B) Walls
- (C) Ground-based floor
- (D) Fenestrations
- (E) External colour and texture

The heat flow through these elements is characterised by their resistance, thermal capacity, absorption, transmission and emission. The materials for these components have to be chosen carefully depending on specific requirements. The thermophysical parameters of materials that must be considered are specific heat, density and thermal conductivity. While the product of the first two determines the energy storage capacity of a material, the third characterises the energy-flow behaviour. These three parameters together define the time lag (or phase shift) and decrement factor.

The former refers to the time delay of heat flow whereas the latter signifies the reduction in the amplitude of heat waves. Thus, depending on the climatic requirements, one would look for materials that would provide the desired thermal storage, time delay and amplitude decrement.



Colour and texture define surface characteristics such as emissivity, reflectivity, absorptivity and roughness. These are vital for heat flow and light distribution. For example, if the roof of a building is painted white, then the transmission of heat can be reduced by upto 80% as compared to a dark colour.

Generally, the building components can be categorised into opaque and transparent elements. For example, a brick wall is an opaque element whereas a glazed window is a transparent element. Transparent elements allow direct solar radiation into the living spaces. Furthermore, an element may also be openable (e.g. skylight, window, door, etc), thereby allowing for air exchanges between the building and its surroundings.

Heat loss or gain from various building components may be reduced by insulating them appropriately. Walls, floors and roofs can be insulated by materials such as polyurethane foam (PUF), or thermocol, either externally or internally. Another mode of insulation is by incorporating an air cavity in the external building envelope. In cavity walls, the air gap inhibits the transmission of the heat into or out of the building as air acts as a bad conductor of heat.



A brief description of various types of insulation is provided in Appendix III.2 [6]. Variations can be achieved by using different insulation materials, adjusting their thickness, and using them in different locations (internal or external). In cavity walls, the property of the air gap can be varied by opting for a ventilated or unventilated air cavity, and adjusting its thickness. It may be noted that water absorption adversely affects the performance of insulation materials.

The heat gain or loss through individual elements depends on whether the building is single storeyed or multi-storeyed. For example, in a typical single storeyed building, maximum heat gain occurs through the roof, whereas in a multi-storeyed building it is through the walls and windows. The heat gain through various building elements on the cooling load of a ground + 4 storeyed residential building for some cities of India is given in Table 3.2 [1]. It is seen that the maximum cooling load on an annual basis, is due to windows (52.9%-64.7%). The next to highest cooling load is due to conduction through walls (26.5%- 36.4%). The cooling loads through the roof and ground are not significant as compared to walls and windows. Windows and walls together account for more than 80% of the cooling load in all cities. Thus, the control of solar gains through windows and conduction through walls should be an important consideration for reducing the cooling loads.



Table 3.2 Heat gain through various building components [1]

Building component	Ahmadabad (223.037 MWh)		Mumbai (201.892 MWh)		Nagpur (198.756 MWh)		Pune (137.764 MWh)	
	Cooling load (MWh)	Percentage of annual cooling load	Cooling load (MWh)	Percentage of annual cooling load	Cooling load (MWh)	Percentage of annual cooling load	Cooling load (MWh)	Percentage of annual cooling load
Walls	81.141	36.4	66.532	33.0	71.151	35.8	36.487	26.5
Roof	18.996	8.5	15.148	7.5	17.845	9.0	12.288	8.9
Ground	4.957	2.2	4.557	2.3	3.000	1.5	-0.129	-0.1
Window (Conduction + Direct Solar)	117.941 (28.563 + 89.378)	52.9 (12.8 + 40.1)	115.654 (17.405 + 98.249)	57.3 (8.6 + 48.7)	106.761 (19.608 + 87.153)	53.7 (9.9 + 43.8)	89.119 (6.180 + 82.939)	64.7 (4.5 + 60.2)

The heat gain through each element can be varied by:

- area of the element
- orientation and tilt of the element
- material properties (U-value, time lag, decrement factor, transmissivity, emmissivity, etc)
- finishes
- control of incoming solar radiation



The roof of a building receives a significant amount of solar radiation. Thus, its design and construction play an important role in modifying the heat flow, daylighting and ventilation. As per Indian Standard I.S. code 3792 - 1978 [4], the maximum value of overall thermal transmittance (U-value) of a roof should not exceed $2.33 \text{ W/m}^2\text{-K}$ in hot-dry, and warm and humid climates. The code recommends that the heat gain through roofs may be reduced by the following methods:

- Insulating materials may be applied externally or internally to the roofs. In case of external application, the insulating material needs to be protected by waterproofing treatments. For internal application, the insulating material may be fixed by adhesive or by other means on the underside of the roofs. A false ceiling of insulation material may be provided below the roofs with air gaps in between. Shining and reflecting material (e.g. glazed china mosaic) may be laid on top of the roof.
- Roofs may be flooded with water in the form of sprays or in other ways. Loss due to evaporation may be compensated by make-up arrangement.
- Movable covers of suitable heat insulating material, if practicable, may be considered.
- White washing of the roof can be done before the onset of each summer.



The second and fourth recommendations would be fully effective if the surfaces are kept clean, without accumulation of dust. The recommended thickness of some insulating materials for roofs is given in Table 3.3. Figure 3.7 [6] shows the reduction of ceiling surface temperature due to some of the above techniques for a flat roof in a hot and dry climate on two consecutive summer days. It is seen that the ceiling surface temperature can be reduced by about 10°C.

A massive roof composed of material such as reinforced cement concrete (RCC) tends to delay the transmission of heat into the interior when compared to lighter roofs such as asbestos cement sheet roofing. Sometimes, the roof is also covered by inverted earthen pots with a layer of earth over them. The earth and the air inside the pots provide good insulation for resisting heat gain. A doubly pitched or curved roof provides a larger surface area for heat loss compared to a flat roof. Thus, both the shape as well as the material have an effect on the performance of the roof.



Table 3.3 Recommended thicknesses of a few insulating materials for roofs [5]

S. No.	Name and Type of Insulating Material	Density Range (kg/m ³)		Maximum Thermal Conductivity Value (W/m-K)	Optimum Thickness (m)			
		Minimum	Maximum		Flat Roof		Sloped Roof	
					NC	C	NC	C
1	Cellular concrete	320	350	0.081	0.05	0.075	-	0.10
2	Coconut pitch concrete	500	600	0.087	0.05	0.075	-	0.10
3	Light weight bricks	400	450	0.081	0.05	0.075	-	0.10
4	Vermiculite concrete	480	560	0.105	0.05	0.10	-	0.125
5	Wood-wool board	350	450	0.076	0.025	0.05	0.025	0.075
6	Foamtex	150	200	0.046	0.025	0.05	0.025	0.05
7	Thermocol	16	20	0.041	0.025	0.035	0.025	0.05
8	Fibreglass	24	32	0.041	0.025	0.035	0.025	0.05
9	Mineral wool	48	64	0.041	0.025	0.035	0.025	0.05
10	Fibre insulation board	200	250	0.053	0.015	0.025	0.015	0.205

NC: Non-air-conditioned

C: Air-conditioned

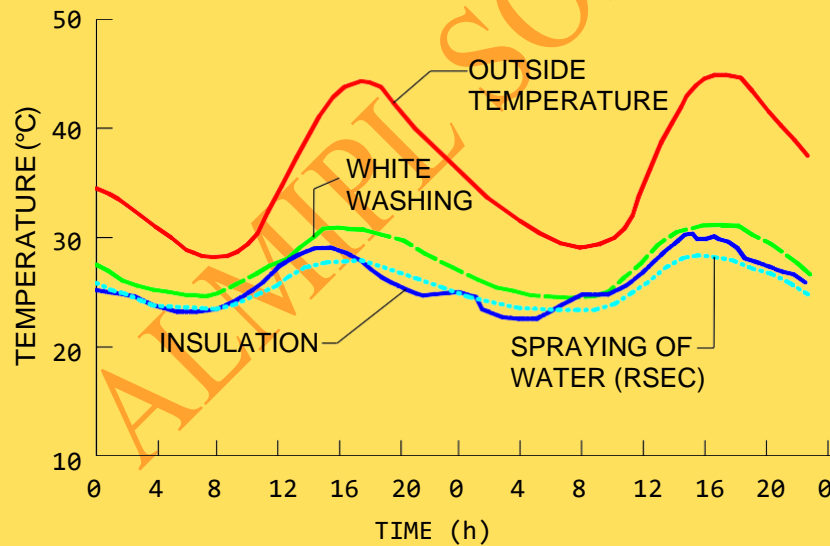

Fig. 3.7 Relative performance of different techniques on a flat roof [5]



The performance indicators such as U-values (thermal transmittance), damping, thermal performance index and thermal time constant of commonly used flat and sloped roofs have been discussed in SP:41 (S&T):1987 [5].

The roof can also be used advantageously for effective ventilation and daylighting by incorporating vents and skylights respectively.

(A) Walls

Walls constitute a major part of the building envelope and receive a large amount of direct radiation. Depending on whether the need is for heating or cooling, the thickness and material of the wall can be varied to control heat gain. The resistance to heat flow through the exposed walls may be increased in the following ways:

- The thickness of the wall may be increased
- Cavity wall construction may be adopted.
- The wall maybe constructed out of suitable heat insulating material, provided structural requirements are met.
- Heat insulating material may be fixed on the inside or outside of the exposed wall. In the case of external application, overall water proofing is essential.
- Light colored whitewash or distemper may be applied on the exposed side of the wall.



The performance indicators, such as U-values (thermal transmittance), thermal damping, thermal performance index and thermal time constant of some typical wall constructions have been discussed in SP:41 (S&T):1987 [5]. The I.S. code 3972-1978 [4] specifies that the U- values of exposed walls should not exceed 2.56 W/m²-K in hot and dry, and hot and humid regions. In warm and humid regions, they should not exceed 2.91 W/m²-K.

(B) Ground-based Floors

Heat is transferred by conduction from the building to the ground through the floor which is in contact with the ground. The transfer of heat between the building and the ground occurs primarily via the perimeter of the building, and to a lesser extent through the central portion of the floor. In warmer climates, this heat loss is desirable from the point of view of comfort. On the other hand, in cold climates, heat loss through the ground needs to be minimised and hence insulation may be provided. The effectiveness of insulation under a floor will depend on factors such as the moisture content and temperatures of the ground. If the moisture content is high or the temperature is low, the tendency for heat to be lost through the floor to the ground will increase.



In these instances, insulation (typically of U-value = $0.09 \text{ W/m}^2\text{-K}$) of thickness of 50mm and depth of 600mm should be provided along the entire perimeter of the slab. To improve performance, the entire slab should be insulated. Foundation insulation using foam board on the inside face of the foundation wall may also be provided. This protects both during construction and during the life of the building.

(C) Fenestration (openings)

Fenestration is provided for the purposes of heat gain, daylighting and ventilation. Their pattern and configuration form an important aspect of building design. Appropriate design of openings and shading devices help to keep out sun and wind or allow them into the building. Ventilation lets in the fresh air and exhausts hot room air, resulting in cooling.

While planning the position of a window, it must be remembered that the tendency of hot air is to rise. Openings at higher levels would naturally aid in venting the hot air out. The size, shape and orientation of the opening affect the speed and flow of air inside the building. For example, openings on opposite walls relieve high pressure on the windward side, permitting good cross-ventilation of the interior space. Also, a small inlet and large outlet increases the velocity and distribution of airflow through the room.



The percentage changes in wind speed in a room due to various window locations and orientations are presented in Fig.3.8 [5]. A negative sign indicates that the wind speed has decreased and a positive sign indicates an increase.











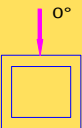
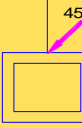

LOCATION OF WINDOWS	PERCENTAGE CHANGE IN VELOCITY OF AIR AS A FUNCTION OF ORIENTATION OF WIND (%)	
	0°	45°
		
	0	0
	-10	+40
	-10	-15
	-15	0
	-15	0
	0	0
	-10	+40
	-10	-15
	0	-60
	-20	-10
	-20	-60



Fig. 3.8 Effect of window location on indoor air motion [5]

Windows are usually glazed, that is, provided with glass. Generally, glass is transparent to solar radiation but opaque to long wave radiation. This characteristic can be used to heat a building interior by promoting heat gain. This is desirable in winter, but may cause overheating in summer. For reducing solar gain during summer, the window size should be kept minimum in the hot and dry regions. For example, in a city like Ahmadabad, the number of uncomfortable hours in a year can be reduced by as much as 35% if glazing is taken as 10 % of the floor area instead of, say, 20%. Thus, though natural light is introduced into the building through glazed openings, skylights, lightshelves, or clerestories, the amount of light and glare that enters needs to be controlled. This can be achieved by providing openable shutters and movable covers like curtains or venetian blinds (section 3.2.3). Besides, tinted glazing or glazing with surface coatings can be used to control solar transmission, absorption and reflection. For example, the direct transmission of solar radiation through a 6mm thick absorbing glass can be reduced by about 45% (Fig. 3.9). Reflective glass is usually made by coating the glass with a layer of reflective material or low emittance layer.



Reflectivity could vary depending on whether the coating is on the outer or inner face of the glass (Fig. 3.10). Glazing of these types can reduce heat gain without obstructing viewing. They are usually used for windows which cannot be shaded externally. cause overheating in summer. For reducing solar gain during summer, the window size should be kept minimum in the hot and dry regions. For example, in a city like Ahmadabad, the number of uncomfortable hours in a year can be reduced by as much as 35% if glazing is taken as 10 % of the floor area instead of, say, 20%. Thus, though natural light is introduced into the building through glazed openings, skylights, lightshelves, or clerestories, the amount of light and glare that enters needs to be controlled. This can be achieved by providing openable shutters and movable covers like curtains or venetian blinds (section 3.2.3). Besides, tinted glazing or glazing with surface coatings can be used to control solar transmission, absorption and reflection. For example, the direct transmission of solar radiation through a 6mm thick absorbing glass can be reduced by about 45% (Fig. 3.9). Reflective glass is usually made by coating the glass with a layer of reflective material or low emittance layer. Reflectivity could vary depending on whether the coating is on the outer or inner face of the glass (Fig. 3.10).



Glazing of these types can reduce heat gain without obstructing viewing. They are usually used for windows which cannot be shaded externally. cause overheating in summer. For reducing solar gain during summer, the window size should be kept minimum in the hot and dry regions. For example, in a city like Ahmadabad, the number of uncomfortable hours in a year can be reduced by as much as 35% if glazing is taken as 10 % of the floor area instead of, say, 20%. Thus, though natural light is introduced into the building through glazed openings, skylights, lightshelves, or clerestories, the amount of light and glare that enters needs to be controlled. This can be achieved by providing openable shutters and movable covers like curtains or venetian blinds (section 3.2.3). Besides, tinted glazing or glazing with surface coatings can be used to control solar transmission, absorption and reflection. For example, the direct transmission of solar radiation through a 6mm thick absorbing glass can be reduced by about 45% (Fig. 3.9). Reflective glass is usually made by coating the glass with a layer of reflective material or low emittance layer. Reflectivity could vary depending on whether the coating is on the outer or inner face of the glass (Fig. 3.10).

Glazing of these types can reduce heat gain without obstructing viewing. They are usually used for windows which cannot be shaded externally.



cause overheating in summer. For reducing solar gain during summer, the window size should be kept minimum in the hot and dry regions. For example, in a city like Ahmadabad, the number of uncomfortable hours in a year can be reduced by as much as 35% if glazing is taken as 10 % of the floor area instead of, say, 20%. Thus, though natural light is introduced into the building through glazed openings, skylights, lightshelves, or clerestories, the amount of light and glare that enters needs to be controlled. This can be achieved by providing openable shutters and movable covers like curtains or venetian blinds (section 3.2.3). Besides, tinted glazing or glazing with surface coatings can be used to control solar transmission, absorption and reflection. For example, the direct transmission of solar radiation through a 6mm thick absorbing glass can be reduced by about 45% (Fig. 3.9). Reflective glass is usually made by coating the glass with a layer of reflective material or low emittance layer. Reflectivity could vary depending on whether the coating is on the outer or inner face of the glass (Fig. 3.10). Glazing of these types can reduce heat gain without obstructing viewing. They are usually used for windows which cannot be shaded externally.

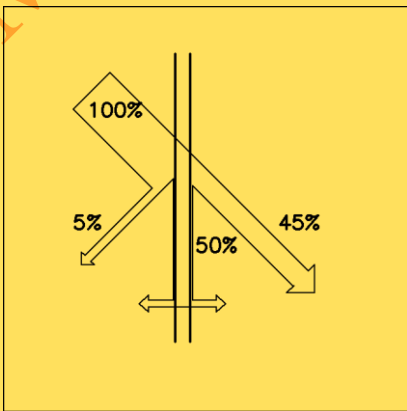

Fig. 3.9 Transmission properties of absorbing glass (6 mm thick)



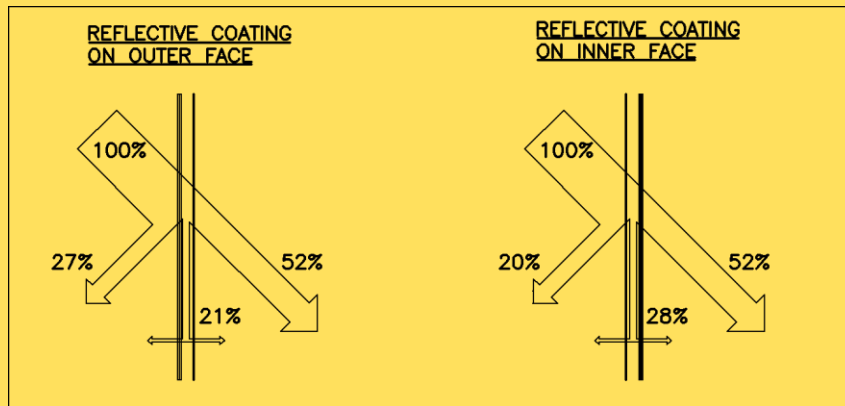

Fig. 3.10 Transmission properties of reflecting glass (6 mm thick)

I.S. Standard 3792-1978 [4] recommends that in the hot and arid, hot and humid, warm and humid and cold zones, no exposed window should have a shade factor of more than 0.5 and a transmittance (U-value) of more than $6.51 \text{ W/m}^2\text{-K}$ for unconditioned buildings; for conditioned buildings, the corresponding values are 0.4 and $3.8 \text{ W/m}^2\text{-K}$ respectively.

The thermal transmittance (U-values) of some doors and windows are given in Fig.

3.12 [5]. For heat insulation of exposed windows and doors, suitable methods should be adopted to reduce both solar heat and heat transmission



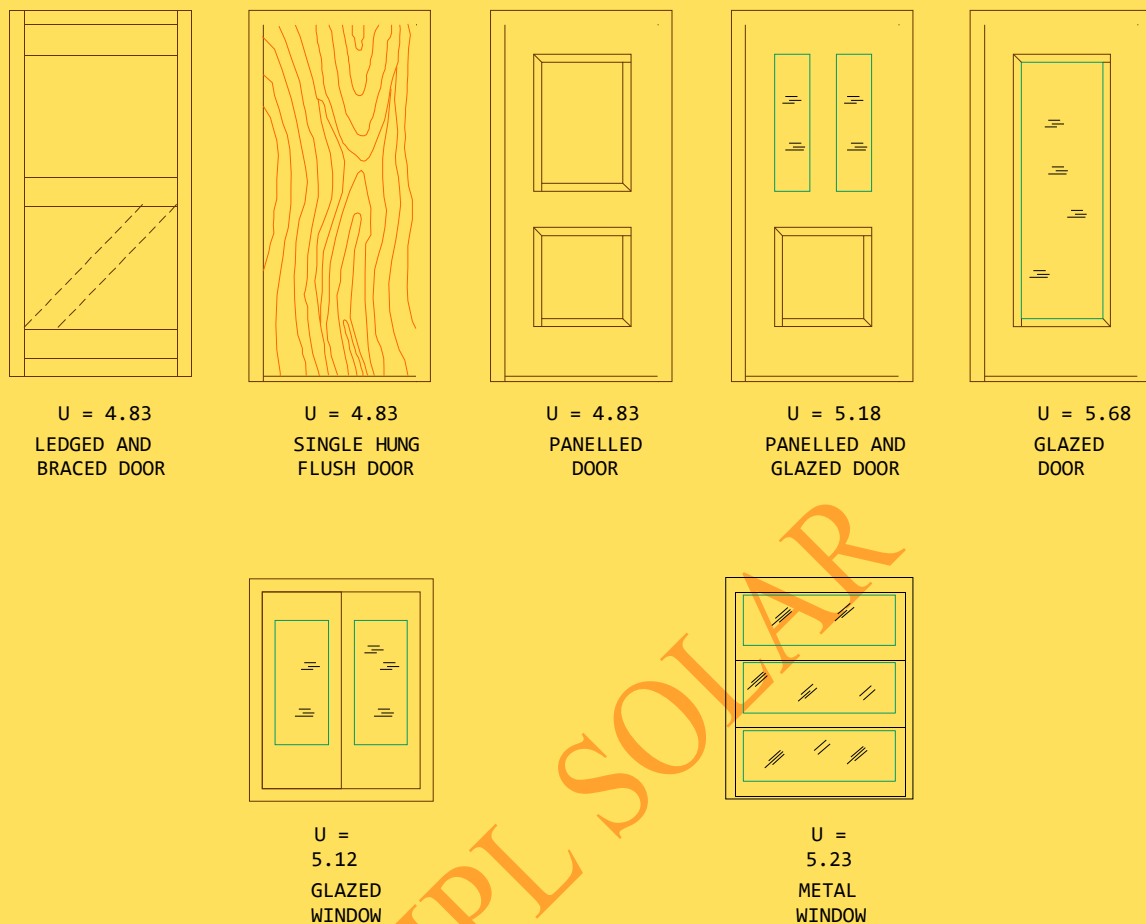

Fig. 3.11 Thermal transmittance of doors and windows [5]

This can be achieved by the following means:

- external shading such as louvered shutters, and sun breakers such as chajjas
- internal shading such as curtains and venetian blinds
- use of heat resistant glasses/ films
- use of double or triple glasses with air space in between (glasses are held apart by spacer bars and a desiccant is used to remove moisture)



Information regarding various types of glazing and their properties is given in Appendix III.3. Under the initiatives of the International Energy Agency (Task 18), a large number of institutes and research organisations are developing advanced glazing materials. The target is to develop the scientific, engineering and architectural basis necessary to support the appropriate use of advance glazing in buildings and other solar applications.

Modern research has brought about significant developments in advanced glazing systems, in the form of new glazing types and window system encapsulations. There are many approaches to advanced glazing system design. These include smart windows, evacuated glazings, transparent insulation materials, monolithic and granular aerogels, low-emittance coatings, angular selective transmittance coatings, holographic and prismatic materials, and thermochromic and liquid crystal devices [7,8]. Commercial systems now exist for a few cases and are being developed for the remaining ones. A basic explanation of energy-efficient glazing has recently been reported by Bandyopadhyay [9]. A few of the advanced glazing systems are discussed briefly.



(i) **Spectrally selective glazing**

Spectrally selective glazing permits some portions of the solar spectrum to enter through it while blocking others. The glazing admits as much daylight as possible while preventing transmission of as much solar heat as possible. Consequently, such glazing when used in windows significantly reduces building energy consumption and peak demand; the capacity of the building's cooling system might also be downsized because of reduced peak loads. The spectral selectivity is achieved by a microscopically thin, low-emissivity (low-E) coating on the glass, or on a film applied to the glass, or suspended within the insulating glass unit.

Spectrally selective glazings can be combined with other absorbing and reflecting glazings to provide a whole range of sun control performance. They can be used in windows, skylights, glass doors, and atria of commercial and residential buildings. It may be noted that these glazings may not provide glare control even if solar gain is reduced.

Spectrally selective glazings offer a number of advantages such as:

- They are more transparent than tinted glazing, enabling occupants to have an unimpeded view and a sense of connection to the outdoors.



- They offer better night views than reflective and dark tinted glazings.
- From the exterior, the appearance of spectrally selective glazing is clear, and not mirrored or heavily tinted.

(ii) Angular selective solar control

From the point of view of daylighting of a building, the objective is to block or reflect direct sun light and admit diffuse light. Angular selective façades provide such control based on the sun's angle of incidence on the façade. These have high transmittance at low angles of incidence and much lower transmittance at slightly higher angles of incidence compared to normal glazing. Consequently, the solar radiation gets transmitted to the building interior during winter (due to lower elevation of the sun) and is prevented from entering the building when the sun has slightly higher elevations.

Variations on this theme include between-pane louvers, or blinds with a mirrored upper surface; these can be used in the clerestory portion of the window wall. In case of exterior glass lamellas (louvers), the upper surface can be treated with a reflective coating. These systems fully or partially block direct sun and redirect



sunlight to the interior ceiling plane, given seasonal adjustments. Conventional louvered or venetian blind systems enable users or an automated control system to tailor the adjusted angle of blockage according to solar position, daylight availability, glare, or other criteria.

Frit is the most common angle-selective coating. It consists of a ceramic coating, either translucent or opaque, which is screen printed in small patterns on a glass surface. The pattern used controls the light based on its angle of incidence. The colour of frit controls reflection or absorption, the view and/or visual privacy. Visual transparency can also be controlled by applying frit to both sides of the glass to make it appear transparent in some angles and opaque in others. Angle-selective materials can be thought of as a series of fins or overhangs within a piece of glass, which filter or block light.

(iii) **Smart windows**

Smart windows are characterised by their ability to vary the visible light as well as solar radiation. This is achieved by incorporating a chromogenic material in the window. Generally, this is done in the form of a thin film having photochromic, thermochromic or electrochromic properties. As the terms suggest, these devices are activated by light, heat and electricity respectively.



Electrochromic windows

An electrochromic window is a thin, multi-layer assembly sandwiched between traditional pieces of glass. The outer two layers of the assembly are transparent electronic conductors. The next one is a counter-electrode layer and an electrochromic layer, with an ion conductor layer in between. When a low voltage is applied across the conductors, the ions move from the counter-electrode to the electrochromic layer. This causes the assembly to change color. When the voltage is reversed, the ions move from the electrochromic layer back to the counter-electrode layer; this restores the device to its previous clear state. The windows operate on a very low voltage -- one to three volts -- and use energy only to change their condition, and not to maintain any particular state. The glass may be programmed to absorb only part of the light spectrum.

Thermochromic windows

Thermochromic windows alter their properties due to heat. In response to changes in the ambient temperature, clear thermochromic glazings become diffused. Among the thermochromic technologies, gel-based coatings seem to be the most promising. In addition to automatically changing from clear to diffuse in response to heat, the glazings also turn white and reflective, thereby reducing the transmission of solar heat. This property can reduce air conditioning costs significantly when the outside is quite hot.



As one cannot see through the window once it loses its transparency, this glazing is probably better suited for skylights rather than view windows.

Photochromic windows

Photochromic windows respond to changes in light, much like sunglasses that darken when one moves from a dim light to a bright one. They work well to reduce glare, but don't control heat gain. This is because the amount of light that strikes a window does not necessarily correspond to the amount of solar heat a window absorbs. Photochromic windows are still in the development stage and are yet to be tested successfully on a large-scale and commercial level.

Smart windows hold promise for reducing energy demands and cutting air conditioning and heating loads in the future. They offer the next major step in windows that are increasingly sophisticated and energy efficient.

(D) External colour and texture

The nature of the external surface finish determines the amount of heat absorbed or reflected by it. A smooth and light-coloured surface reflects more heat and light; a rough textured surface causes self-shading and increases the area for re-radiation. White or lighter shades have higher solar reflectivity and therefore are ideally used for reducing heat gain in warmer climates. Moreover, a heavy texture on these light-coloured surfaces helps to reduce the glare.



Dark colours absorb more radiation, which increases heat gain through the surface, and can thus be used in cooler regions. An example of the effect of the colour of external surfaces in the four cities of Ahmadabad, Mumbai, Nagpur and Pune is given in Table 3.4 and 3.5 [3]. It is seen that in all cities, a white painted surface outperforms all other colours in terms of lowering room temperatures.

Table 3.4 Effect of colour of external surfaces on room temperatures in different climatic zones [3]

Colour (Absorptivity, Emissivity)	Ahmadabad (Hot and Dry)					Mumbai (Warm and Humid)				
	Yearly min (°C)	Yearly max (°C)	Yearly avg (°C)	H ₂₅ ^Y (h)	H ₃₀ ^Y (h)	Yearly min (°C)	Yearly max (°C)	Yearly avg (°C)	H ₂₅ ^Y (h)	H ₃₀ ^Y (h)
White painted surface (0.3, 0.9)	20.6	42.2	29.7	7140	3908	24.5	34.6	29.6	8605	3350
White-washed surface (0.4,0.9)	20.8	42.5	30.0	7319	4123	24.8	34.9	29.8	8667	3654
Dark grey surface (0.9,0.9)	21.9	44.0	31.1	7830	5599	26.0	36.1	30.9	8760	5535
Cream surface (0.4,0.9)	21.2	43.0	30.4	7498	4739	25.3	35.3	30.2	8760	4320
Red surface (0.6, 0.9)	21.2	43.1	30.4	7498	4739	25.2	35.4	30.2	8760	4412

H₂₅^Y: Number of hours for which room temperatures exceed 25 °C in a year

H₃₀^Y: Number of hours for which room temperatures exceed 30 °C
in a year min : minimum; max : maximum; avg :
average



Table 3.5 Effect of colour of external surfaces on room temperatures in different climatic zones [3]

Colour (Absorptivity, Emissivity)	Nagpur (Composite)					Pune (Moderate)				
	Yearly min (°C)	Yearly max (°C)	Yearly avg (°C)	H ₂₅ ^Y (h)	H ₃₀ ^Y (h)	Yearly min (°C)	Yearly max (°C)	Yearly avg (°C)	H ₂₅ ^Y (h)	H ₃₀ ^Y (h)
White painted surface (0.3, 0.9)	20.4	40.1	29.2	7067	2957	22.0	34.4	27.4	7078	1926
White-washed surface (0.4,0.9)	20.7	40.3	29.5	7220	3139	22.3	34.7	27.7	7319	1957
Dark grey surface (0.9,0.9)	22.2	41.7	30.9	7923	4408	23.7	35.9	28.8	8171	2682
Cream surface (0.4,0.9)	21.4	40.9	30.1	7494	3715	23.0	35.2	28.2	7894	2172
Red surface (0.6, 0.9)	21.3	40.9	30.1	7494	3687	22.9	35.2	28.1	7864	2140

3.3 PASSIVE HEATING

3.3.1 Direct Gain

Direct gain is a passive heating technique that is generally used in cold climates. It is the simplest approach and is therefore widely used. In this technique, sunlight is admitted into the living spaces directly through openings or glazed windows. The sunlight heats the walls and floors, which then store and transmit the heat to the indoor environment. The main requirements of a direct gain system are large glazed windows to receive maximum solar radiation and thermal storage mass.



During the day, the affected part of the house tends to get very hot, and hence, thermal storage mass is provided in the form of bare massive walls or floors to absorb and store heat. This also prevents overheating of the room. The stored heat is released at night when it is needed most for space heating. Carpets and curtains should not be used to cover floors and walls used as storage mass because they impede the heat flow rate. Suitable overhangs for shading and openable windows for ventilation must be provided to avoid overheating in the summer. Thus a direct gain system has the following components: (a) glazing - to transmit and trap the incoming solar radiation, (b) thermal mass - to store heat for night-time use, (c) insulation - to reduce losses at night, (d) ventilation - for summer time cooling, and (e) shading - to reduce overheating in summer. A schematic diagram showing the components of direct gain system is given in Fig. 3.12. Reflectors may be provided outside windows to increase the efficiency of the direct gain system. Clerestories and skylights may also be used to gain heat. For example, clerestories used as a direct gain system in a restaurant in New Mexico, USA can maintain an indoor temperature of about 15°C as compared to an outside temperature of -1.0°C [10].

Direct gain is the most common, simple, cheap and effective heating approach. However, overheating, glare and degradation of building materials due to ultraviolet radiation are some of its disadvantages.



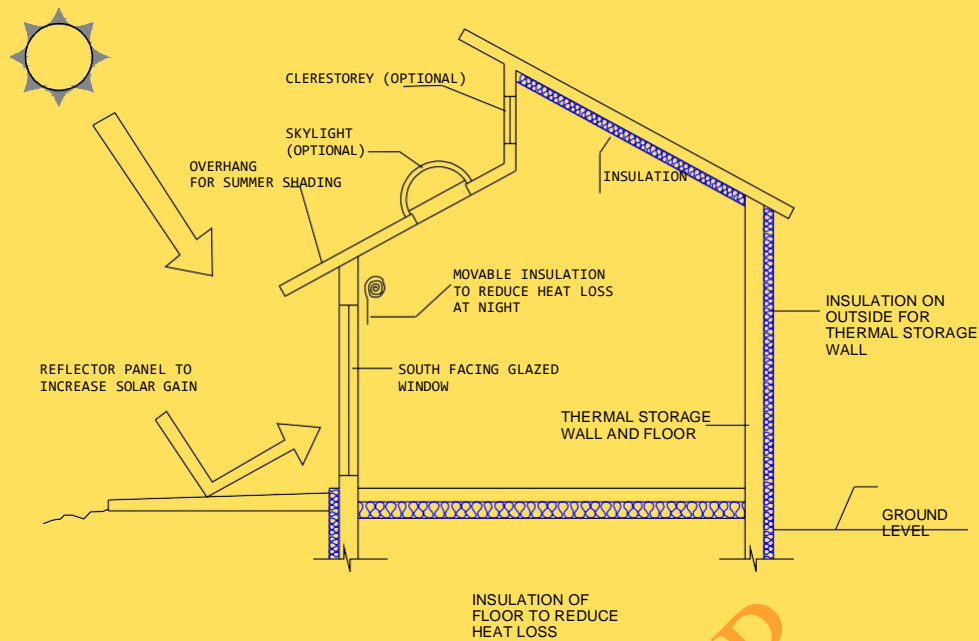

Fig. 3.12 Components of a direct gain system

Components: Glazed windows

The principal function of a glazed window in a direct gain approach is to admit and trap solar energy so that it can be absorbed and stored by elements within the space. In winter, the sun's altitude is low and its movement is in the southern part of the sky in northern hemisphere. Hence, the window must face south in the northern hemisphere as it receives maximum solar radiation in this direction. Large expanses of south-facing windows used for heating in direct gain applications can, if properly designed, gain significantly more energy than they lose. The orientation of the window may vary by upto 20% east or west of the south without significantly affecting the thermal performance.



A slight east-of-south orientation may be desirable to allow the sun to penetrate the living space in the mornings.

Table 3.6 Effect of window-types in cold climates

Place	Annual load (GJ/year)	
	Single clear glass	Double clear glass
Srinagar	212.0	172.0
Leh	416.0	329.0

Table 3.6 presents the effect of window-types for a conditioned residential bungalow in for Srinagar and Leh which represent (i) cold and cloudy, and (ii) cold and dry climates respectively. It is seen that a significant reduction in heat loss can be achieved by using double glazing. Triple glazing may be provided in places that experience severe winters.

Figure 3.13 shows an example of a wooden-framed, double glazed and double rebated window. The extra rebate is provided to reduce infiltration.



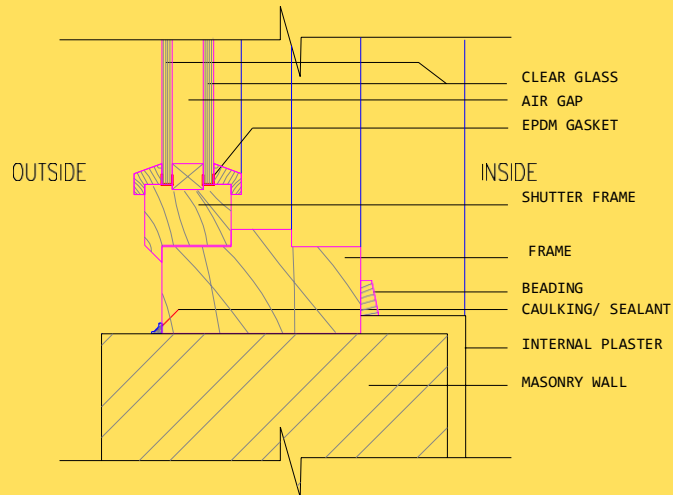

Fig. 3.13 Details of a double glazed window

Thermal Storage Mass

In direct gain systems, solar energy can be stored in the floor, walls, ceiling, and/or furnishings of the living space if these components have sufficient capacity to absorb and store heat for use at night. Materials such as concrete, brick and water have this capability and can be used effectively in direct gain applications. Also used, are phase change materials (PCM) such as salt or wax that store thermal energy when they melt and release heat when they solidify [11].

Care should be taken to ensure a balanced distribution of mass throughout the living space. In general, a thin material spread over a larger area will perform better than thick material concentrated in one part of the space.

Generally, for every square metre of south-facing glazing area, 30 percent of storage area should be provided to receive direct sunlight.



The thickness of the storage floor material should be 50 to 150 mm, and that of walls should be 50 to 100 mm [12]. The masonry units used should be solid with full mortar bedding. Storage mass exposed to direct sunlight should be dark in colour to absorb more heat. It is generally more thermally efficient to provide thicker rather than thinner storage mass. However, there is an optimum thickness. For example, in case of the floor being used as the storage mass, the storage effect increases as its thickness increases. For a thickness beyond 100mm, the rate of increase in the storage effect is not significant. In fact, the performance decreases for thicknesses greater than 200mm.

Variations and Controls:

Thermal storage materials can be concrete, bricks, stone or water in containers. The thermal mass is typically located in the external walls, internal walls or floors that receive direct sun. Direct gain can be admitted through various forms of openings like clerestories, skylights, greenhouses or glass curtain walls. The colour of internal surfaces also plays an important role in absorbing radiation, and distributing of daylight. Darker colors absorb more heat than lighter colors as pointed out earlier. As far as the distribution of light is concerned, lighter shades are preferred indoors.



Thus, the storage surfaces should be of medium-dark colour, whereas lightweight materials should have light colours to reflect sunlight on the masonry walls or floors. Reflectors may be provided outside the windows, clerestories and skylights to increase the efficiency of the direct gain system.

Reflectors can be placed horizontally above or below a window. In cases where physical obstructions (e.g. trees or other buildings) on or around the building site shade the window, the provision of reflectors can often increase solar collection by about 30-40%. They are usually panels coated on one side with a material of high reflectance. When the windows extend all the way to the ground (e.g. french window or patio door), the reflectors are simply laid on the ground in front of them. They should be placed so that they slope slightly away from the window to increase the amount of reflected sunlight and to facilitate drainage (5% is recommended). The size of the reflector panel should be of the same width as the window, and roughly 1 to 2 times the height. To be economically and aesthetically justifiable, they should also be insulated so that they can serve as movable insulation when not in the reflecting mode. It should be noted that reflecting panels may cause glare and/ or overheating problems within the direct gain living spaces.



Light-coloured exterior landscape elements such as patios or terraces, can also serve as reflectors. They will not perform as efficiently as panels with high reflectance, but they will reduce the possibility of glare and overheating.

While windows can admit and trap a great deal of solar energy during clear sunny days, they can also lose a great deal of heat during prolonged overcast periods and at night. Providing some form of movable insulation can result in a significant increase in overall thermal performance. In severe climates, windows may be net energy losers if movable insulation is not provided. There are two basic types of movable insulation: those applied to the outer face of the collector, and those applied on the inside. Both can effectively reduce heat loss during the heating season (winter) and when used like shades, at preventing excessive heat gain during the cooling season (summer). These devices can be hand operated or motor driven. Care must be taken to ensure a very tight seal between the insulation and the collector to avoid heat loss around the edges of the insulation.

To avoid excessive heat gain in the cooling season and to increase overall system performance, some provision should be made for shading the windows. Common external shading devices are overhangs (fixed or adjustable), trellises, awnings, louvers (horizontal or vertical, fixed or adjustable), and wing walls. Interior shading devices, while often not as thermally effective as exterior units, are generally easier to operate and maintain.



Common interior shading devices include roller shades, blinds, drapes, and movable panels. For optimum overall performance of the system, these shading elements should also be designed to provide insulation during the day in the cooling season and at night in the heating season. Exhausts and vents can be employed to cool the interior spaces through ventilation when the temperature rises beyond the comfort level.

Heat losses can also be controlled by providing insulation on the storage mass. Direct gain storage walls and floors that are exposed to the outside should be insulated on their exterior surfaces. Insulating the interior surface of a storage wall effectively nullifies any thermal storage capability of the wall, because it prevents solar energy from being absorbed by the wall. Therefore, insulation should be placed on the outside of any exterior wall, above and below the plinth that is used for thermal storage. Similarly, floors should also be insulated on the outside.

Remarks and Practical Considerations:

A direct gain system causes large temperature swings (typically 10 °C) because of large variations in the input of solar energy to the room. Joint reinforcement should therefore be provided to control cracking caused by thermal movement and shrinkage. Expansion joints should be provided at the connection between floors and masonry walls to prevent cracking. Insulation must be protected wherever it is exposed.



Cement plaster over chicken mesh or wire lath or other methods may be employed. Where damp-proofing is used, it should be allowed to completely cure before applying insulation. Care must be taken to ensure a tight fit between any insulation and the glass to reduce heat loss at the edges. Continuous sill sealer is recommended to provide protection against infiltration. In cooler climates, continuous insulation should be used under the slab which is used as storage mass, and a vapour barrier should be placed directly under the slab.

Example:

The Himurja office building located in Shimla, Himachal Pradesh employs the direct gain technique for heating in a cold and cloudy climate. Inside temperatures of 18 to 28 °C compared to outside air temperatures of 9 to 15 °C in January have been recorded. The building does not require any auxiliary heating during winters [13].

3.3.2 Indirect Gain

3.3.2.1 Thermal storage wall

Thermal storage wall systems are designed primarily for space heating purposes. In this approach, a wall is placed between the living space and the glazing such that it receives maximum solar radiation (generally the southern face of the building in the northern hemisphere). This prevents solar radiation from directly entering the living space; instead, the collection, absorption, storage and control of solar energy occur outside it. The glazing reduces heat loss to the ambient.



Windows can also be integrated into the thermal storage wall to provide light, view and some direct gain heating. Movable insulation can be applied outside the glazing façades or in the airspace between the glazing and the storage wall to reduce heat loss at night. Shading and reflecting devices are typically placed on the exterior.

Different types of storage walls are discussed in this section.

(a) Trombe wall

A Trombe wall is a thermal storage wall made of materials having high heat storage capacity such as concrete, bricks or composites of bricks, block and sand. A typical Trombe wall is illustrated in Fig 3.14. The external surface of the wall is painted black to increase its absorptivity and is placed directly behind the glazing with an air gap in between. Solar radiation is absorbed by the blackened surface and is stored as sensible heat in the wall. In an unvented wall, the stored heat slowly migrates to the interior, where it heats the adjacent living space. If properly designed, the wall can provide adequate heat to the living space throughout the night. Some of the heat generated in the air space between the glazing and the storage wall is lost back to the outside through the glass. The hotter the air in the airspace, the greater is the heat loss. This heat loss can be reduced by venting the storage wall at the top and bottom. Such units are called as 'vented Trombe walls'.



Some of the heat generated in the air space between the glazing and the storage wall is lost back to the outside through the glass. The hotter the air in the airspace, the greater is the heat loss. This heat loss can be reduced by venting the storage wall at the top and bottom. Such units are called as 'vented Trombe walls'.

The air, in the space between the glazing and the wall gets warmed up and enters the living room through the upper vents. Cool room air takes its place through the lower vents, thus establishing a natural circulation pattern (thermocirculation) that needs no mechanical means for moving the air.

ALMIPL SOLAR

4th Floor 4B, Mandira Apartments,
North Boag Road, T-Nagar Chennai- 600 017
Email: Solarbazaarpl@gmail.com
Web: www.almipl.com
Mobile: 94452 30332 / 9383132332

Green Energy Promoters



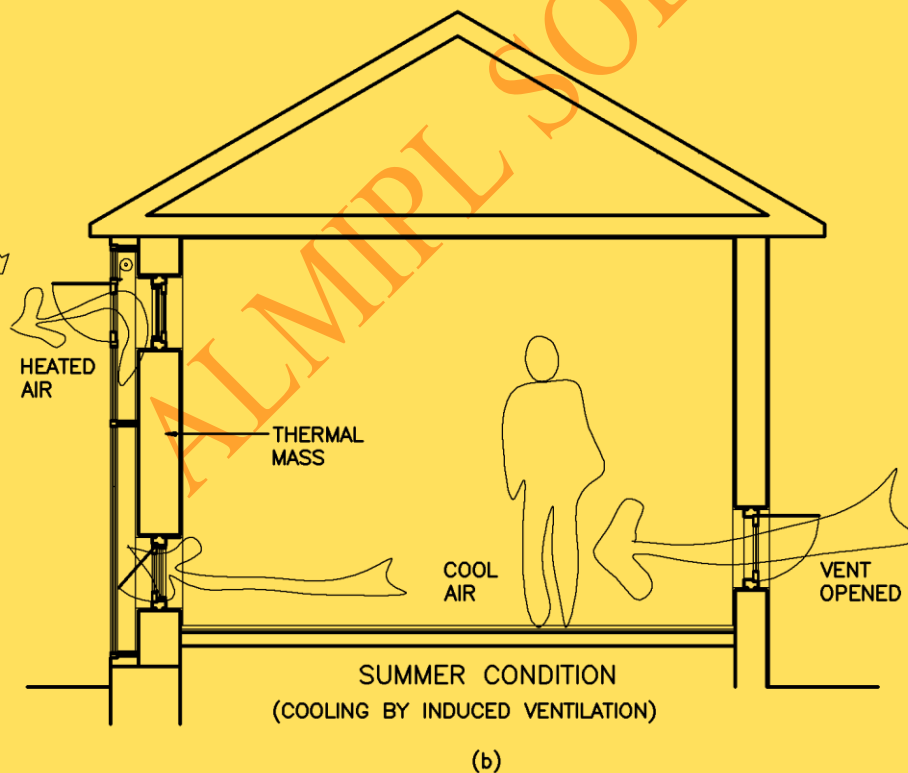
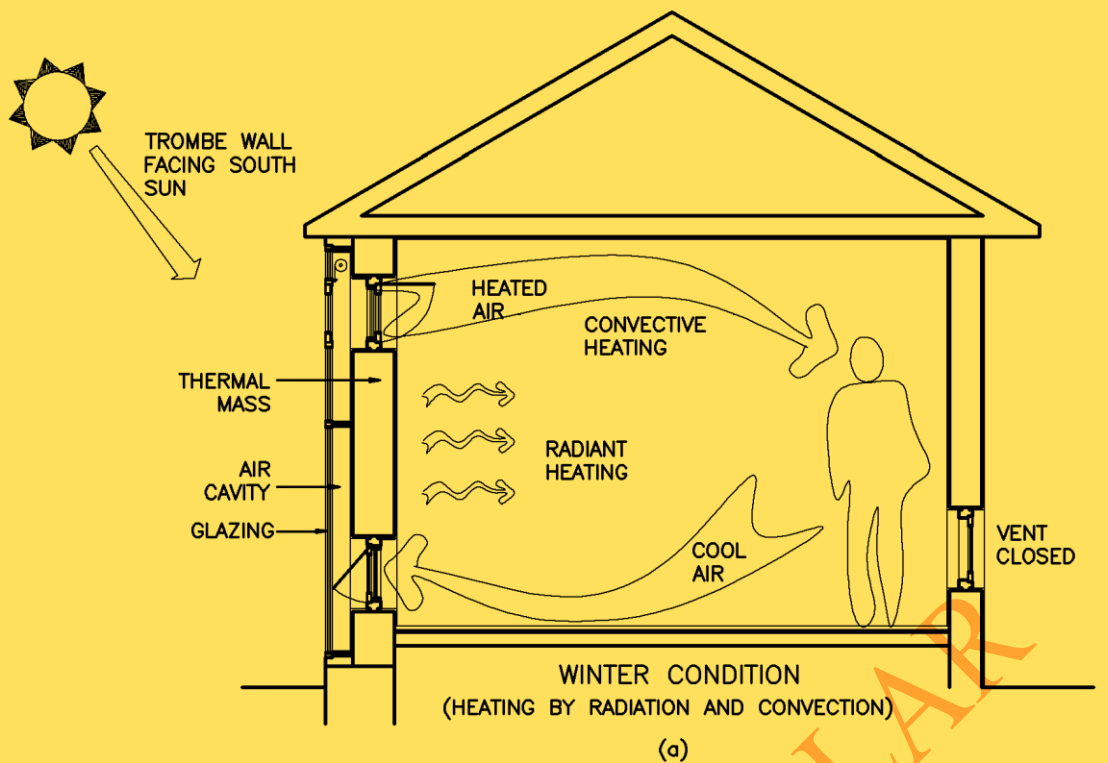

Fig. 3.14 Working principle of a Trombe wall



A part of the absorbed heat is conducted through the wall and is transferred to the living space by convection and radiation. This process is illustrated in Fig. 3.14a. Thus, vented Trombe walls are suitable for buildings having daytime use, such as offices and shops. Care should be taken to ensure that the circulation pattern does not reverse itself at night. This is because temperatures in the airspace drop at night leading to warm air from the living space flowing into the airspace. This warm air then pushes the cooler air in the airspace into the living room. Thus, the heat may actually be lost from the living space to the environment by the Trombe wall. To prevent such reverse circulation, simple backdraft dampers or openable louvers need to be provided on the upper vents.

In a vented system, due to circulation of hot air, the amount of heat available for storage by the Trombe wall is reduced. An unvented system does not lose heat in this way and thus has the advantage of storing a greater percentage of the solar energy available to it than does a vented wall. This stored heat is, however, not readily available for immediate use, instead, it is transferred slowly into the living area.



Hence, un-vented Trombe walls are provided for residences, which require heating mainly during the night. Furthermore, in cold climates where daytime as well as night-time heating requirements are high, it is desirable to provide a certain amount of heat directly to the living space. In such situations, a vented wall may be provided. In more moderate climates where daytime heating is not as important as night-time heating, an unvented system may be preferable. The thickness and thermal properties of the wall materials determine the time lag of the heat travelling from the outside surface of the unvented wall to the interiors. This may vary from several hours to an entire day.

A Trombe wall offers several advantages. Glare, and the problem of ultraviolet degradation of materials is eliminated as compared to the direct gain system. The time lag due to the storage wall ensures that heat is available at night when it is needed most. Besides, one is able to provide sufficient storage mass in a relatively small area. However, a storage wall can block view and daylight. It is desirable to provide movable insulation between the glazing and storage wall; otherwise, the stored heat can be lost to the ambient at a very high rate at night due to the difference in temperature between the ambient and the storage wall. It is noteworthy that in buildings with thermal storage walls, the indoor temperature can be maintained at about 15°C when the corresponding outside temperature may be as low as - 11°C [10].



During summer months, when the sun's altitude is high, an overhang is required to cut off direct sunshine. The Trombe wall can provide induced ventilation for summer cooling of the space as shown in Fig. 3.14b. Here, the heated air in the collector space flows out through exhaust vents at the top of the outer glazing, and air from outside enters the space through openings on the cooler side to replace the hot air. This continuous air movement cools the living space.

A section of the Trombe wall is shown in Fig. 3.15 giving various construction details. It consists of a number of components such as, (a) glazed walls - to transmit the incoming solar radiation, (b) thermal mass - to store heat for night-time use, (c) air space for trapping heat, and in case of vented wall, to transfer heat by convection, (d) movable insulation in air space- to reduce losses at night, (e) vents in glazed walls and storage walls - for circulating hot air, and in summer for exhausting heat, and (f) shading - to reduce overheating in summer. Reflectors may be provided outside the glazing to increase the efficiency of the Trombe wall system. Generally, the thickness of the storage wall is between 200-450 mm, the air gap between the wall and the glazing is 50-150 mm, and the total area of each row of vents is about 1% of the storage wall area [10,12].



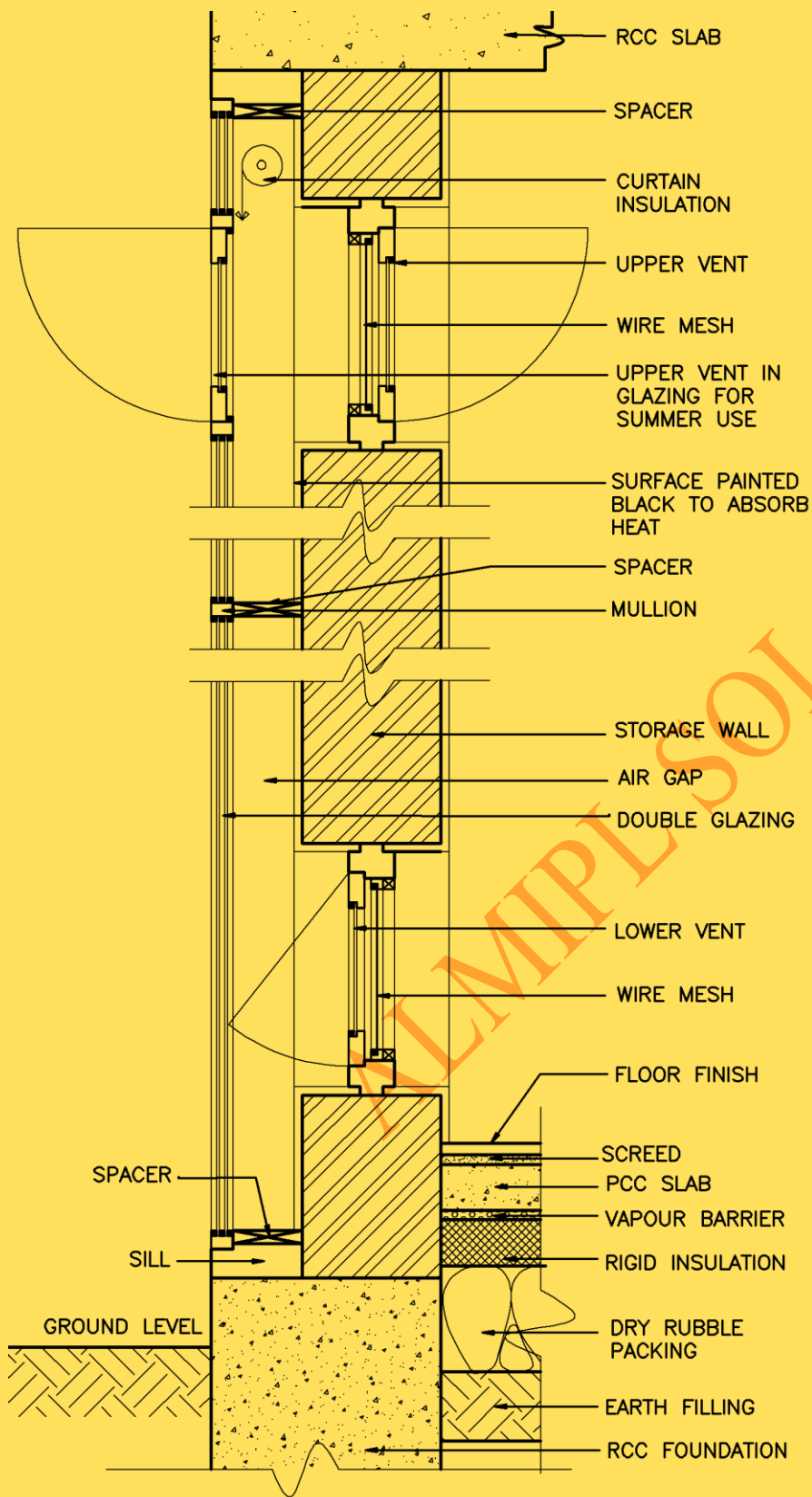

Fig. 3.15 Details of a Trombe wall

Components:

Glazing

The principal function of the glazing in a Trombe wall is to admit and trap solar energy so that it can be absorbed and stored by the thermal storage wall. The Trombe wall must face south in the northern hemisphere to receive maximum solar radiation. A small variation in the orientation of the wall (east or west of the south) does not significantly affect the thermal performance. Using double glazing reduces heat loss compared to a single glazing. If metal framed glazing is used, it should be separated from the wall either by a space or a wood block, to avoid conductive heat losses from the wall through the metal to the outside. Seasoned wood may be used in place of metal. Paints applied on the frames should be able to withstand high temperatures which may go upto 60 °C. The frames should allow for significant expansion (minimum 12mm), particularly in unvented walls. Caulking and sealants must be able to accommodate such movement. The glazing material itself can be glass, fibreglass, acrylic or polycarbonate. and should be able to withstand high temperatures. Vents may be provided in the glazing panels for summer-time exhaust of hot air from the cavity to the ambient. The surface area of the glazing should be equal that of the storage wall.



Thermal Storage Mass

The effect of a thermal storage wall is largely determined by the wall's thickness, type of material and the colour of the external surface. Materials with high thermal capacity (concrete, brick, and water) and phase change materials (PCM) can be used effectively in Trombe walls. The recommended thickness for different materials is given in Table 3.7 [10]. The table also shows the effect of the wall thickness on the daily fluctuation of indoor air temperature. Generally, it is seen that the thicker the wall, the better is its performance. The values given in the table are for clear winter days, and correspond to a wall with its external surface painted dark and having double glazing.

Table 3.7 Recommended thickness for various thermal storage walls and their effect on indoor temperatures [10]

Material	Thermal conductivity (W/m-K)	Recommended thickness (m)	Approximate indoor temperature fluctuation ¹ as a function of wall thickness (°C)				
			0.2m	0.3m	0.4m	0.5m	0.6m
Adobe	0.519	0.20 to 0.30	10.0	3.9	3.9	4.4	-
Brick (common)	0.727	0.25 to 0.35	13.3	6.1	3.9	-	-
Concrete (dense)	1.731	0.30 to 0.45	15.6	8.9	5.6	3.3	2.8
Brick (magnesium additive ²)	3.462	0.40 to 0.60	19.4	13.3	9.4	6.6	5.0
Water ³	0.575 (at 10°C)	0.15 or more	10.0	7.2	6.1	5.6	5.0



1. Assuming a double glazed wall. Values are given for clear winter days.
2. Magnesium is added to give bricks a dark colour and also increase thermal conductivity.
3. If water is used in tubes or other circular containers, use at least 0.23 m diameter tubes or 0.15 m³ of water for every 1 m² of glazing.

Storage mass exposed to direct sunlight should have dark color to absorb solar radiation. To improve performance, selective coatings can also be applied on the exposed surface of storage walls. These coatings have high absorptivity for incoming solar radiation and low emissivity for re-radiation. The interior surface of the wall may be painted or left untreated. The area of the vents for thermocirculator should be about 2% of the wall area, divided evenly between upper and lower vents.

Variations and controls:

The distribution of heat into the living space can be almost immediate or delayed depending on air circulation. Furthermore, the delay can be varied depending on the thickness of the wall, and the time-lag property of the wall materials. If the vents are provided with dampers, the air flow can be controlled.



Shading, reflector panels and insulation controls are more or less the same as those for direct gain systems. Overheating during summer may be prevented by using fixed exterior shades or movable curtains within the air space. For optimum performance, these curtains or shading devices should also be designed to provide insulation during the day in the cooling season, and at night in the heating season.

Another variation is due to wall materials. In addition to conventional building materials, Phase change materials (PCM) can be used as storage materials for thermal storage wall, because they have a greater ability to store and release heat during phase changes. Also, for a given amount of heat storage, PCMs require less space than any sensible storage and are much lighter in weight. They are therefore, convenient for use in retrofit of buildings.

Commonly used PCMs are hydrated salts and hydrocarbons. Of the hydrocarbons, paraffin wax has been very popular in building applications. Also used are, (a) a mixture of stearic acid, paraffin (80%) and mineral oil, and (b) sodium decahydrate. While hydrated salts are inexpensive and can store more heat than a hydrocarbon, their properties degrade with prolonged use; they are also corrosive. On the other hand, hydrocarbons are flammable and require careful handling.

Remarks and Practical Considerations:

The Trombe wall due to its complex construction and weight, may require special foundations and footings.



The availability of daylight and view to the exterior are affected by the presence of a Trombe wall, and therefore must be taken care of by other design features. The temperatures in the air space can be quite high. Joint reinforcement should therefore be provided to control cracking caused by thermal movement and shrinkage. Cracking can be prevented by providing expansion joints at the connection between concrete or masonry floors, and the storage walls. Sealants and caulking should also be of high quality to avoid degradation due to high temperatures. Continuous sill sealer is recommended to provide protection against infiltration. Periodic maintenance is required to check whether sealants have cracked. Joints also need to be inspected; otherwise the performance of the Trombe wall may be affected due to infiltration of cold ambient air. The accumulation of dust on the glass and on the dark absorbing surface would deteriorate the performance. Hence, provision for cleaning the glass and wall needs to be made. This has been done in the HP state Co-operative Bank in Shimla, which has incorporated the Trombe wall as a passive heating systems in the building.

Example:

Trombe walls have been successfully used in the cold regions of Leh. In case of LEDeG (Ladakh Ecological Development Group) Hostel at Leh, the temperatures inside the



bedrooms have been recorded to be above 8 °C corresponding to outside temperatures of -17 °C [13].

(b) Water wall

Water walls are based on the same principle as that of the Trombe wall, except that they employ water as the thermal storage material. Water walls can store more heat than concrete walls because of the higher specific heat. A water wall is a thermal storage wall made up of drums of water stacked up behind glazing. It is painted black externally to increase the absorption of radiation. The internal surface can be painted with any other colour and can be in contact with the interior space directly, or separated by a thin concrete wall or insulating layer.

A view of the same is shown in Fig. 3.16. As the storage in the water wall is a convective body of mass, heat transfer is very rapid compared to a masonry wall. Table 3.8 gives the typical wall area required for maintaining the living space temperatures between 18 and 24°C for different ambient conditions on a clear day (solar radiation > 4 kWh/m²-day) [11].



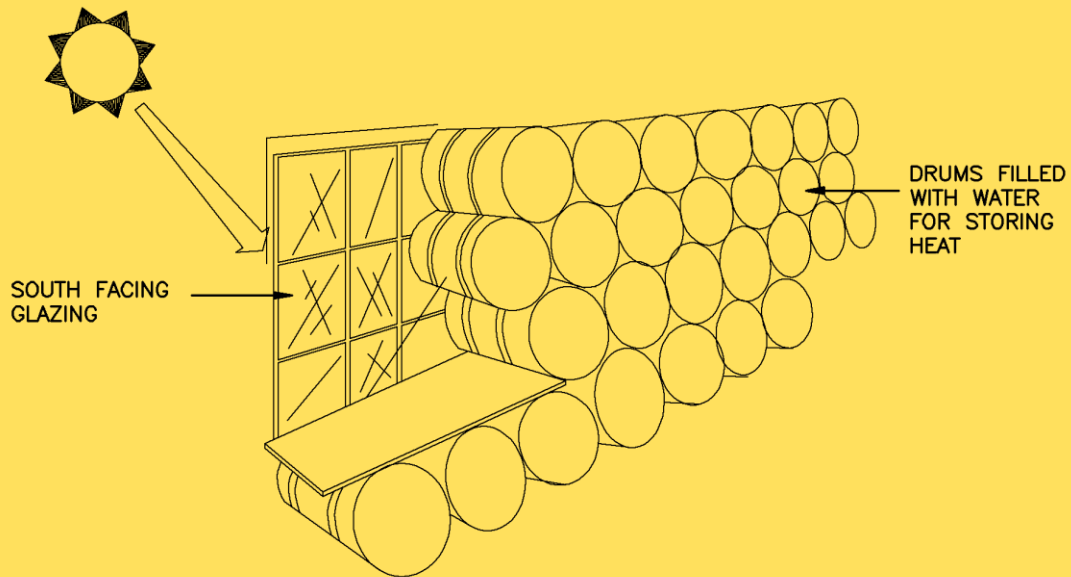

Fig. 3.16 Water wall

Table 3.8 Sizing a water wall for different climatic conditions (Calculated for a mean U-value of 1.9 to 2.1 W/m²-K for a room) [10,11]

Average winter outdoor temperature (°C)	Area of wall needed for each square metre of floor area (m ²)
-4.0	0.70
-1.0	0.55
2.0	0.45
5.0	0.35



Variations and controls:

A large storage volume provides longer and greater storage capacity, while smaller units enable faster distribution. In order to fix the quantity of water, the thumb rule is usually taken as 150 litres of water per square metre of south oriented water wall. A variety of containers like tin cans, bottles, tubes, bins, barrels, drums, etc., provide different heat- exchange surfaces to the storage mass ratio. Care should be taken to ensure that steel and metal containers are lined with corrosion resistant materials. Also, the water should be treated with algae retardant chemicals. Troughs should be provided as a precaution against leakage of water from containers or from condensation.

Heat transfer through a water wall is much faster than through a Trombe wall. So, a control on the distribution of heat is needed, if it (heat) is not immediately necessary for the building. This can be affected by using a thin concrete layer or insulating layer, or by providing air circulation through vents. Buildings like schools or government offices which work during the day, benefit from the rapid heat transfer in water walls. To reduce heat losses, the glazing of the water wall is usually covered with insulation at night. Overheating during summer may be prevented by using movable overhangs.



(c) Transwall

Transwall is a thermal storage wall that is semitransparent in nature. It partly absorbs and partly transmits the solar radiation. The transmitted radiation causes direct heating and illumination of the living space. The absorbed heat is transferred to the living space at a later time. Heat loss through the glazing is low, as much of the heat is deposited at the centre of the transwall ensuring that its exterior surface does not become too hot. Thus, the system combines the attractive features of both direct gain and Trombe wall systems.

A transwall has three main components:

- Container made of parallel glass walls set in metal frame.
- Thermal storage liquid, which is generally water.
- A partially absorbing plate set at the centre of the transwall, parallel to the glass walls.

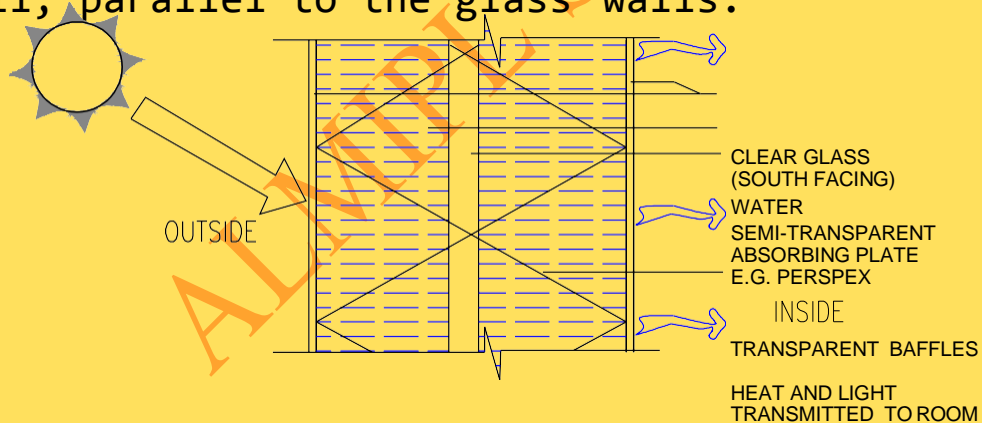

Fig. 3.17 Typical section of a transwall



Figure 3.17 illustrates the typical section of a Transwall. It is installed on the south side of the building (in the northern hemisphere), located directly behind double glazing. To prevent the growth of micro-organisms in the storage, an inhibiting agent may be added.

Variations and controls:

The dimensions of the storage module are dictated by the hydrostatic pressure exerted by the liquid. Also, important, are the considerations of transportation, the method of installation, the ways of filling and draining the module, and attachment of the modules to each other and integration with the building.

As the storage is a convective body of water, the transfer of heat is rapid. This can be regulated by providing baffles and adding a gelling compound. Baffles are transparent plates which connect the module walls with the absorbing plate and prevent water movement. The gelling compound increases the general flow resistance.



Roof top collectors

There are a few interesting examples of passive heating systems that can be incorporated as part of the roof. Thermosyphon air panels and roof radiation traps are examples of such systems. A brief description of each is given in this section.

(A) Thermosyphon air panels

A thermosyphon air panel is essentially an absorbing surface, with minimum thermal inertia on the south face (in northern hemisphere) of the building and a glazing over it, thus forming a solar air heater. It absorbs incident solar radiation and heats up the air in the absorber-glazing space. A well-insulated collector limits the heat loss to the outside. The hot air forces itself into the living space through the vents, and warms it up. Cooler air takes its place and the cycle is repeated. In addition to heating the space, heat can also be stored for later use by passing the hot air through a storage mass. Figure 3.18 and 3.19 illustrate the working principle and detail section of this type of collector respectively.

The storage is generally the inner structure of the building like an internal wall and/or a concrete ceiling which is not exposed to the outside, thereby minimising the heat loss to the outside. Besides, during the evening and night hours, the well-insulated collector serves as a thermal buffer between the house and the external atmosphere, and eliminates the need for movable insulation.



Dampers and ducts can be used to control the air-flow either to the storage unit or directly into the living space. The thermal storage may be suitably designed to realise a desired time lag for the distribution of heat to the living space.

In summer, when relief from high temperatures is required, the system can be modified to act as a ventilation device. In this case, the hot air is not allowed to enter the room. On the other hand, the room air enters the collector, gets heated up and is vented out at the top.

This creates a low pressure in the room, leading to cooler air being sucked into the room from windows. This process continues throughout the day and is known as induced ventilation. Such a system is shown in Fig. 3.20.

ALMIP SOLAR



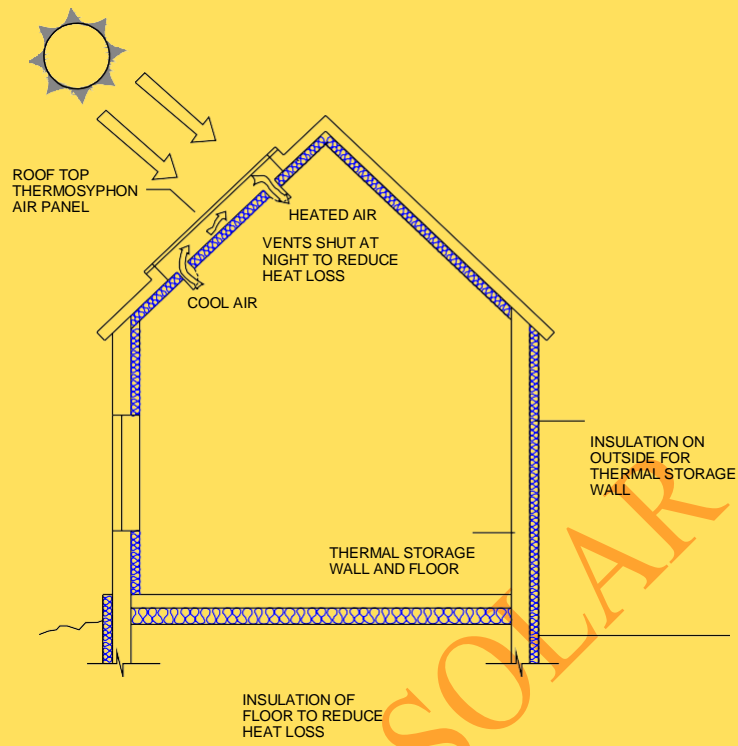

Fig. 3.18 Thermosyphon air panel: working principle

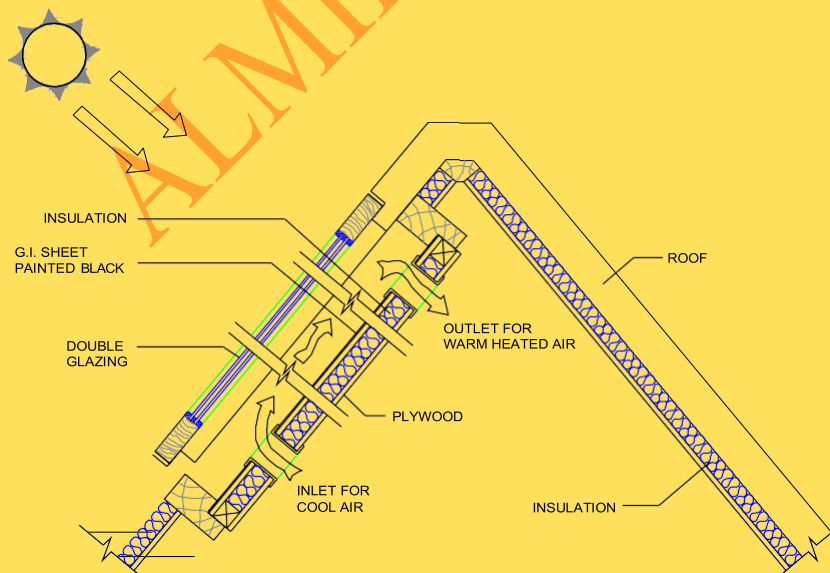

Fig. 3.19 Details of a thermosyphon air panel

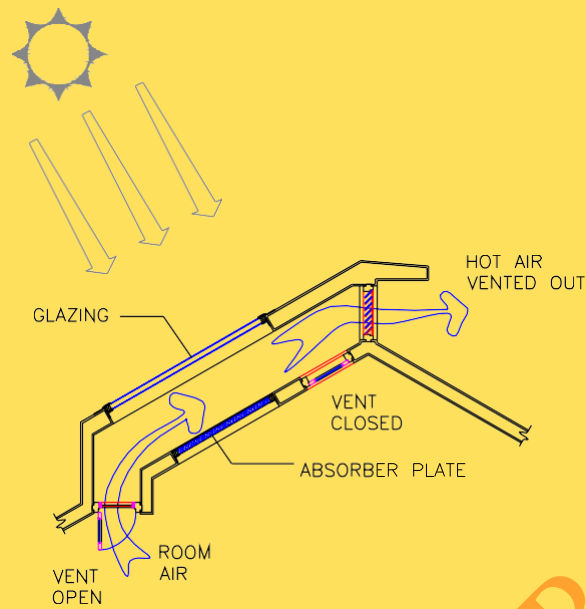

Fig. 3.20 Variation of thermosyphon air panel for summer cooling

(b) Roof Radiation Trap

A roof radiation trap can be used for winter heating and summer cooling. In this technique, the incident solar radiation is trapped and is used for heating the air inside the trap. Some amount of energy is also absorbed by the roof and is conducted through it to be radiated into the living space.



In the northern hemisphere, the trap consists of an inclined south-facing glazing and a north sloping insulated surface on the roof. The latter projects over the glazing to shade it during the summer. Between the roof and the insulation, an air-pocket is formed which is heated by solar radiation. A shutter is used to cover the glazing when desired. Figure 3.21 shows the schematic sketch of a roof radiation trap. A roof can have one or several such units.

In winter (Fig. 3.21a), solar radiation penetrates the glazing and is absorbed by the black roof surface designed to minimise heat loss to the ambient. Further, a movable insulation reduces heat loss through the glazed plane during nights. Part of the absorbed energy is conducted and radiated into the living area through the roof, while the rest is transferred to the air-pocket. This hot air can be drawn to a thermal storage unit (rockbed / water mass) to be used on cold nights or cloudy days.

The system can also be used for summer cooling. The insulating plane is covered with a white metal sheet to increase its emissivity. On summer nights, the sheet gets cooled by nocturnal radiation exchanges and in turn, cools the air blown under it (Fig. 3.21b). This coolness is stored in the storage unit and used for cooling the living space during daytime.



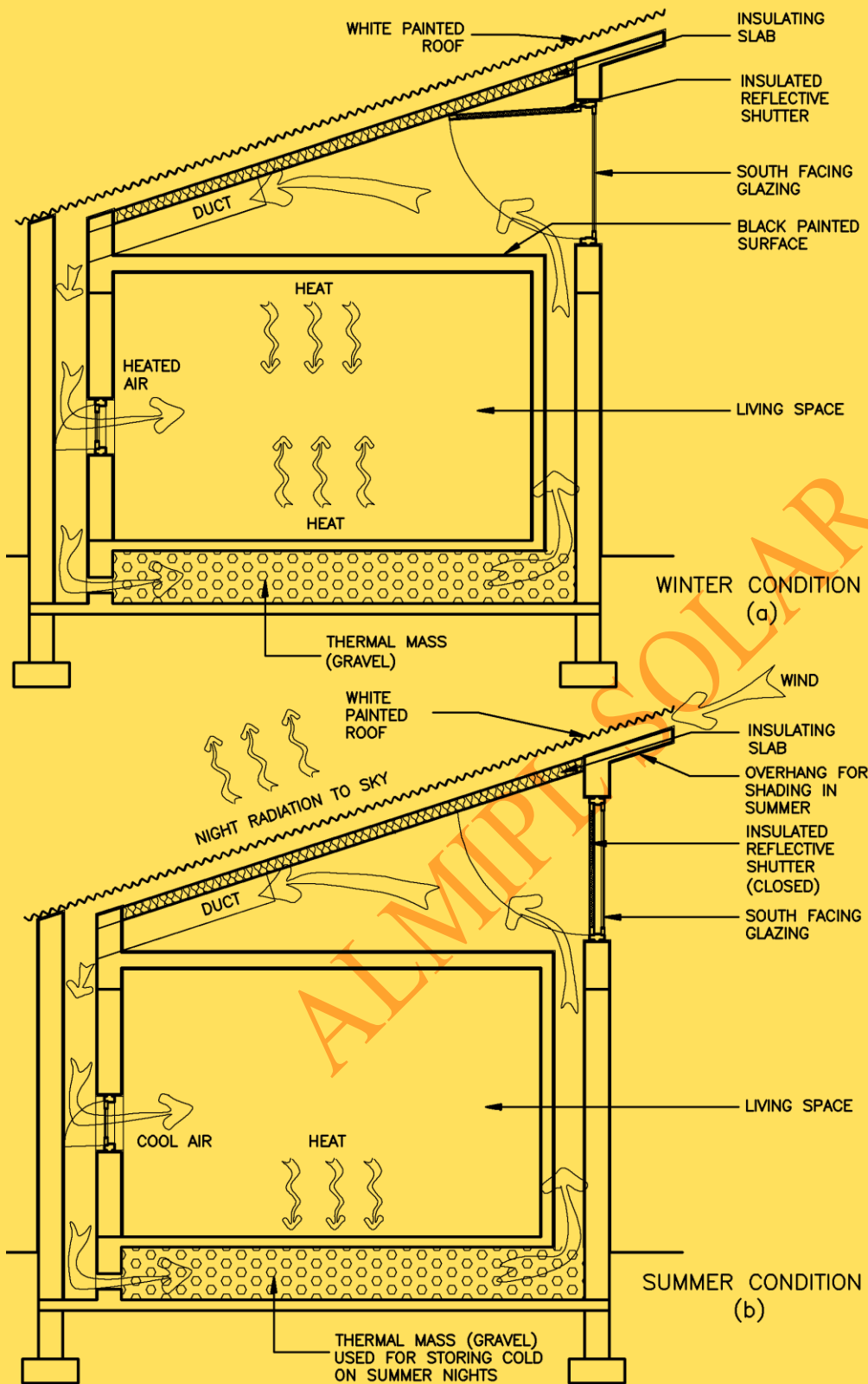

4th Floor 4B, Mandira Apartments,
 North Boag Road, T-Nagar Chennai- 600 017
 Email: Solarbazaarpl@gmail.com
 Web: www.almipl.com
 Mobile: 94452 30332 / 9383132332

Green Energy Promoters



Fig. 3.21 Working principle of a roof radiation trap

The type of roof material and its thickness determine the pattern of heat flow into the living space. A hinged insulating panel inside the radiation trap can help to control the division of heat flow between conduction through roof and convection to storage through air. External insulation can be used to keep summer radiation out and prevent heat loss on winter nights.

3.3.3 Isolated Gain

In isolated gain systems, the solar radiation collection and storage are thermally isolated from the living spaces of the building. This allows in a greater flexibility in the design and operation of the passive concept. The most common example of isolated gain is the natural convective loop. In this system, solar radiation is absorbed to heat air or water.

The warm air or water rises and passes through the storage, transferring its heat. The cooler air falls onto the absorber to get heated up again. Thus, a 'thermosiphoning heat flow' occurs as shown in Fig 3.22.



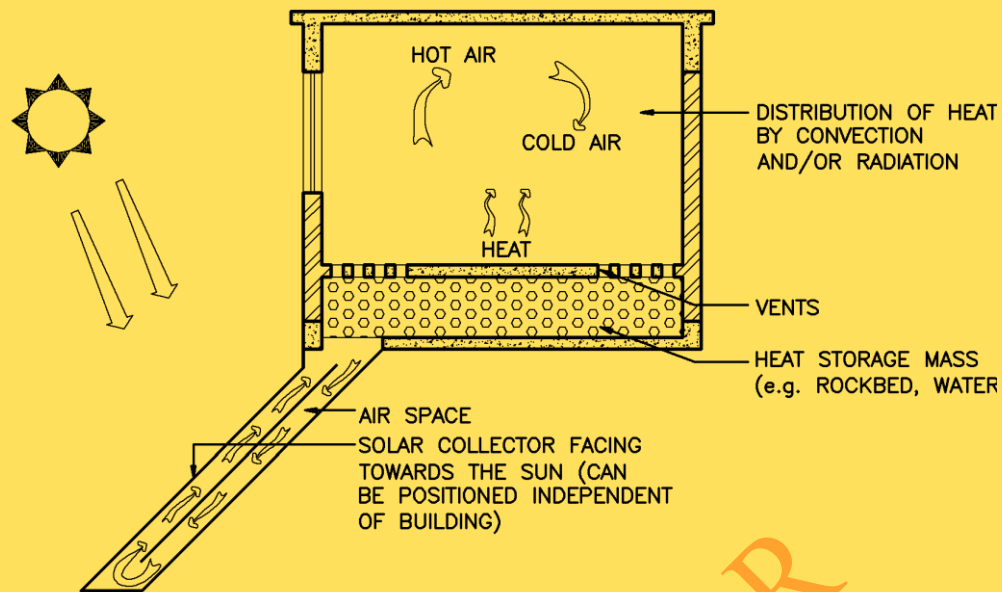

Fig. 3.22 Isolated gain

The basic requirements for this system are:

- a collector, which absorbs the solar radiation to heat the fluid
- a storage mass, which absorbs the heat from the fluid, to be stored for distribution into the living space
- a mechanism to distribute the heat stored in the storage mass

Variations and controls :

The collector can be located at any suitable place and oriented independently of the building for maximum solar gain. Thus the building design can be flexible. The slope of the collector is generally equal to the latitude of the place. Its area may range from 20 to 40 % of the floor area of the living space to be heated. The collector consists of an absorber (usually a corrugated metal plate with a black paint that can withstand temperatures upto 120° C) and glazing.

4th Floor 4B, Mandira Apartments,
North Boag Road, T-Nagar Chennai- 600 017

Email: Solarbazaarpl@gmail.com

Web: www.almipl.com

Mobile: 94452 30332 / 9383132332

Green Energy Promoters



Single glazing is the norm except in severely cold climates where more than one is required to be used. The gap between the glazing and the absorber should be about 5 - 6% of the absorber length.

Variations in the storage materials can be achieved by using different types of materials as well as by varying their location (for example, below the floors and windows or in the wall). The method of distribution of heat from the storage can be either by radiation or convection, or it can also be directly from the collector. If water is used as the working fluid, the hot water can be run through pipes installed in the floor slab, where heat is stored and radiated into the living space. This can be supplemented by a boiler, or fired by wood/gas during extended overcast seasons for maintaining comfort conditions.

If the contact area between the collector space and the storage is not large, then the link between the two can be blocked or disconnected easily to control the performance of the system. It follows that the larger the area of contact, the greater and quicker the heat transfer.

Therefore performance control can be exercised by designing the area of contact between the collector space and storage to meet specific heating demands.



3.3.4 Solarium (Attached Green House / Sunspace)

Sunspaces are essentially used for passive heating in cold climates. This approach integrates the direct gain and thermal storage concepts. Solar radiation admitted directly into the sunspace heats up the air, which, by convection and conduction through the mass wall reaches the living space (as shown in Fig 3.23). A solarium essentially consists of a sunspace or a green house constructed on the south side (in the northern hemisphere) of the building with a thick mass wall linking the two. The sunspace can be used as a sit-out during day as it allows solar radiation but keeps out the surrounding cool air. At night, it acts as a buffer space.

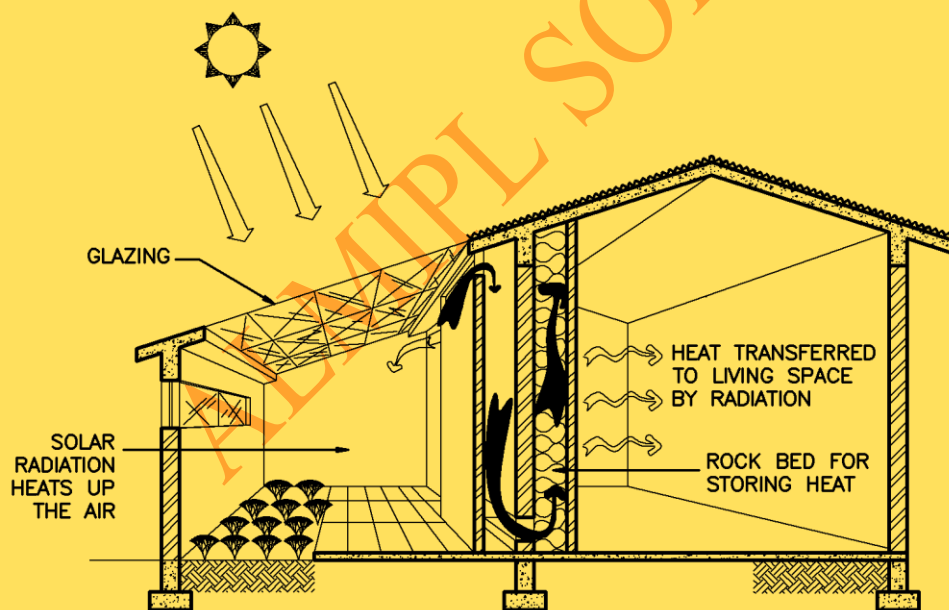

Fig. 3.23 Working principle of a solarium



The basic requirements of this type of building are:

- a glazed south facing collector space attached, yet distinct from the building
- thermal storage link between the collector and living space for heat transfer

Variations and controls:

The location of the sunspace depends on the building design and orientation of the sun. The area of contact between the sunspace and the living space determines the size of the former.

The thermal mass must be located where winter radiation can reach it. Floors, walls, benches, rock bed or covered pools of water can be used to store heat. Glazing should preferably be sloped by about 45° in overcast and 60° in clear and sunny areas. The storage walls are generally 200 - 450 mm thick. If a rockbed storage is used, then the typical size is

0.75 - 1.25 m³ per square metre of the glazed area. Ideally, it should cover the entire floor, the typical rock size being about 5 -7.5 cm in diameter [12].

The temperature inside the sunspace must be controlled depending on its usage. Shading to prevent overheating in summer, and movable insulation and shutters to prevent heat loss in winter can be provided.



If the sunspaces are used for plantation or as a green house, humidity control must be incorporated to prevent mould from growing on the storage mass or other materials kept inside.

General remarks: The manner of arrangement of the passive components, namely. glazing, insulation, collector, storage and the living space to be heated or cooled, differentiates one passive system from the other. The variations and controls that each type offers have been indicated. Further possibilities within each class are created by using different types of heat storage materials. Sometimes passive systems also use small fans for direct control over convective heat distribution. These may be referred to as 'hybrid' systems.

The various passive concepts outlined so far essentially represent passive heating systems wherein attention is given to efficient collection of solar energy. Movable insulating curtains are provided to prevent unwanted heat loss to the environment at nights as well as on overcast winter days. However, as indicated, some of them could also be used for passive cooling purposes by changing the mode of operation. But there are certain concepts which are used exclusively for passive cooling. These are outlined in the next section.

3.4 PASSIVE COOLING

The cooling of buildings by using passive methods has evoked great interest.



The underlying principle of passive cooling is to prevent heat from (or at least reduce heat flux) entering the building, or remove heat once it has entered. In this section, we discuss the principles governing each of the concepts used for passive cooling of buildings. The various concepts discussed are ventilation cooling, evaporative cooling, nocturnal radiation cooling, desiccant cooling and earth coupling. The applicability of these concepts depends greatly upon the climatic conditions prevailing in a particular place.

3.4.1 Ventilation Cooling

Ventilation is generally defined as the replacement of stale air by fresh air. It also provides cooling by air movement. Hence, it would be appropriate to define the term ventilation as the supply of outside air to the interior for air motion and replacement of vitiated air. An indoor air speed of 1.5 - 2.0 m/s can cause comfort in warm and humid regions where the outdoor maximum air temperature does not exceed 28 - 32°C [14]. The scheduling of natural ventilation in arid climates (allowing only night-time ventilation) can reduce the maximum indoor temperature by about 5 - 8°C compared to that of the outdoor.

Providing proper ventilation in buildings calls for due consideration in the design phase of buildings.



A faulty design resulting in inadequate ventilation will result in higher energy consumption in the building for creating comfortable indoor conditions. Therefore, the ventilation requirements of different seasons, for different types of occupancies should be determined first. A ventilation system should then be suitably designed to meet the required performance standards.

There are many ways in which ventilation can improve comfort. For example, opening the windows to let the wind in, and thus providing a higher indoor air speed, makes people inside a building feel cooler. This approach is termed as comfort ventilation. In hot environments, evaporation is the most important process of heat loss from the human body for achieving thermal comfort. As the air around the body becomes nearly saturated due to humidity, it becomes more difficult to evaporate perspiration and a sense of discomfort is felt. A combination of high humidity and high temperature proves very oppressive. In such circumstances, even a slight movement of air near the body gives relief. It would, therefore, be desirable to consider a rate of ventilation which may produce necessary air movement. If natural ventilation is insufficient, the air movement may be augmented by rotating fans inside the building.

The air movement indoors is mainly due to stack effect (stratification of temperature) and wind pressure. Manipulating these two effects can considerably improve the ventilation. For example, a solar chimney works mainly on the stack effect. The solar chimney is used to exhaust hot air from the building at a quick rate, thus improving the cooling potential of incoming air from other openings.



Similarly, wind towers use wind pressure for cooling. The wind is captured at the top of the terrace and is diverted to the indoors using wind towers. Windows can also be arranged to take advantage of stack effect and wind pressure. An indirect way of cooling is to ventilate the building only at night to cool the interior mass of the building. During the following day, the cooled mass reduces the rate of indoor temperature rise and thus provides a cooling effect. This strategy is termed as nocturnal ventilative cooling.

This section provides more details about cross ventilation, wind towers, and nocturnal ventilation.

3.4.1.1 Cross ventilation

Requirements for air motion in the early summer and late post-monsoon periods are usually small. These can be easily met by providing adequate cross ventilation through rooms. When a building is cross ventilated during the day, the temperature of the indoor air and surfaces closely follow the ambient temperature. Therefore ventilation in daytime should be considered only when indoor comfort can be experienced at the outdoor air temperature (with acceptable indoor speed).

The indoor wind speed varies due to factors such as the area and location of windows in the room, direction of incident wind, weather shades such as louvers, chajjas, verandahs, etc., and the type of interconnection between different rooms of a building. For example, the available wind velocity in a room with a single window on the windward side is about 10% of



Mobile: 94452 30332 / 9383132332

the outdoor velocity at points up to a distance of one-sixth of room width from the window. Beyond this, the velocity decreases rapidly and hardly any air movement is produced in the leeward end of the room. Therefore, it is better to provide two windows on adjacent or opposite walls to improve ventilation. The window area and the direction of wind affect the performance of this cross ventilation. Figure 3.24 [5] shows how the window area affects the average indoor air velocity. The plot corresponds to the case where there are two windows of identical size on opposite walls; the wind direction is perpendicular or normal to the window. For example, for windows that are 20 percent of floor area, the average indoor wind velocity is about 25 percent of outdoor velocity. wind velocity is about 25 percent of outdoor velocity.

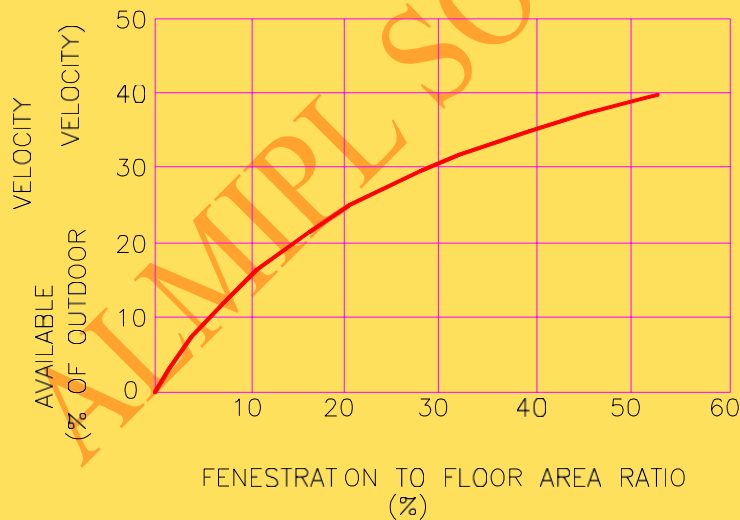

Fig. 3.24 Effect of window area on indoor air speed



3.4.1.2 Wind tower

Wind tower is generally used in hot and dry climates for cooling purposes. The tower is meant to “catch” the wind at higher elevations and direct it into the living space. The air flow passages in the tower may have equal or different areas. The tower may have only one opening facing the wind, if wind is predominantly in one direction, or may have openings in all directions in locations with variable wind directions. Such systems have been used for centuries in West Asian countries for natural ventilation and passive cooling [15,16].

A pre-requisite for using a wind tower is that the site should experience winds with a fairly good and consistent speed. A wind tower operates in various ways according to the time of day and the presence or absence of wind. The cardinal principle of its operation lies in changing the temperature and thereby the density of the air in and around the tower.

The difference in density creates a draft, pulling air either upwards or downwards through the tower, shown schematically in Fig. 3.25. The detail section of a wind tower is given in Fig. 3.26.



Working: Night

The tower area is so designed that the top part provides large heat storage capacity, and also has a large surface area for heat transfer. The tower walls and the internal walls of the air-flow passages absorb heat during the day and release it at night, warming the cool night air in the tower. Warm air moves up creating an upward draft and is exhausted through the openings.

The pressure difference thus created pulls the cool night air through the doors and windows into the building. In the absence of wind, the tower acts as a chimney. The nocturnal radiation through the roof and the external walls brings about further cooling.

4th Floor 4B, Mandira Apartments,
North Boag Road, T-Nagar Chennai- 600 017
Email: Solarbazaarpl@gmail.com
Web: www.almipl.com
Mobile: 94452 30332 / 9383132332

Green Energy Promoters



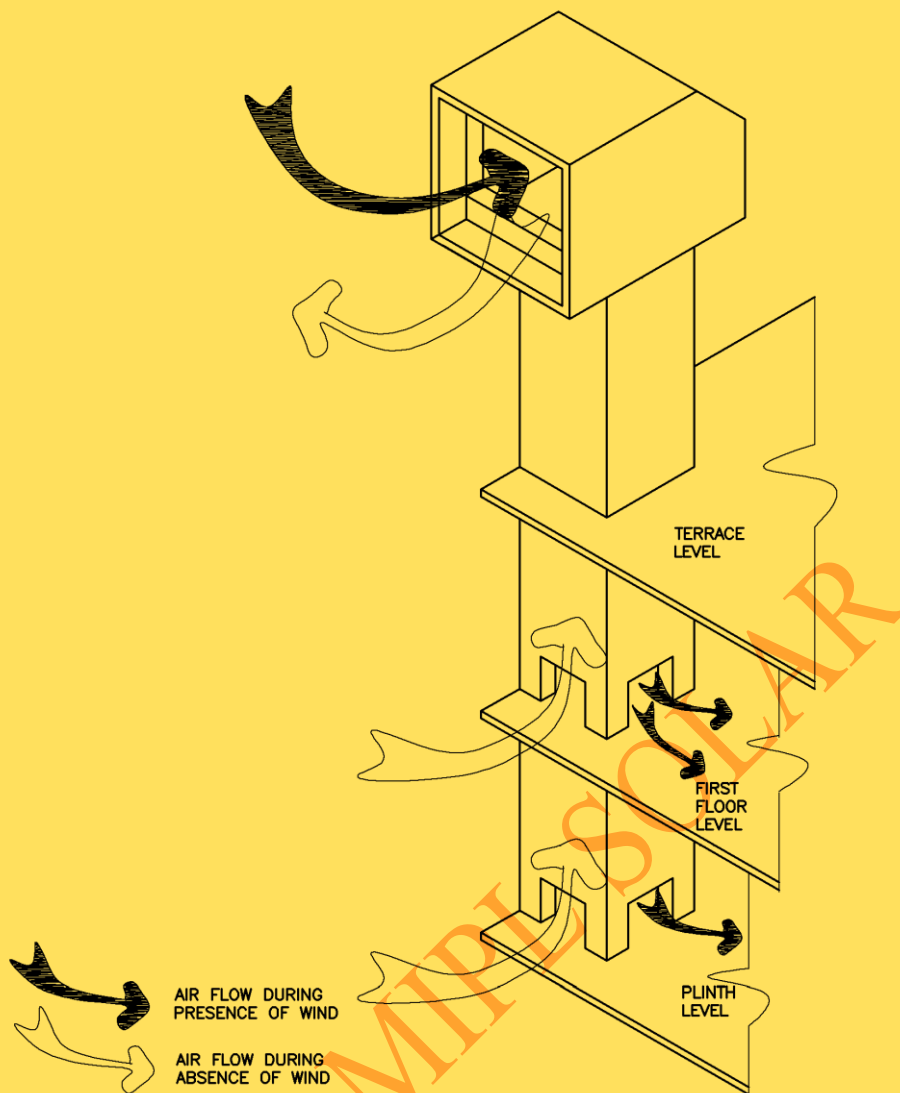

Fig. 3.25 Working principle of a wind tower

In the presence of wind, the cool night air enters the tower and forces itself down into the structure. Though it is warmed slightly during the process, sufficient cooling can be achieved due to forced circulation. Again, cooling due to nocturnal radiation adds to this process.



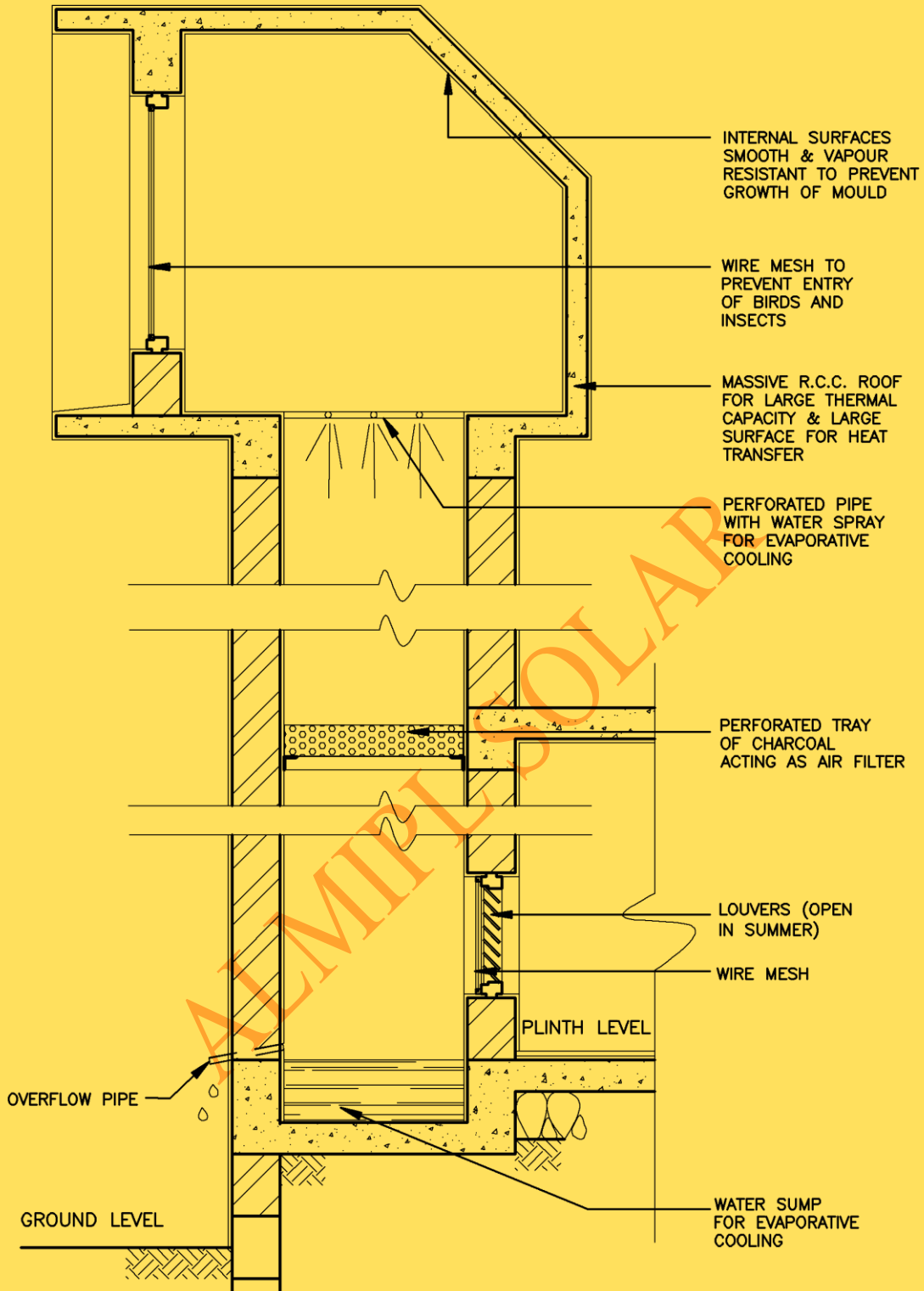

Fig. 3.26 Detail of a wind tower



Working : Day

The hot ambient air coming in contact with the cool upper part of the tower gets cooled. It becomes cold and dense, and sinks through the tower and into the living spaces, replacing the hot air. In the presence of wind, the air is cooled more effectively and flows faster down the tower and into the living area. It must be noted that the temperature of the tower soon reaches that of the ambient air and hence, in the absence of wind, the downward flow ceases, the tower then begins to act like a chimney. The operation of the tower depends greatly on the ambient fluctuations like the wind velocity, air temperature changes, etc.

Variations and controls:

Variations in wind tower design can be achieved by altering tower heights, cross section of the air passages, locations and number of openings, and the location of the wind tower with respect to the living space to be cooled. The variations are aimed at providing the desired air-flow rates, heat transfer area and storage capacity. Air flow through different parts of the buildings can be controlled by the doors and windows.



Due to small storage capacity, the sensible cooling may stop after several hours of operation on hot summer days. In order to improve the efficiency of its operation, evaporative cooling may be introduced. The air flowing down the tower is first sensibly cooled, and then further cooled evaporatively. This can be achieved by providing a shower/spray or dripping of water at top of tower, or a fountain at the bottom. The reduction in the temperature of air can be as much as 10 – 15° C in arid climates [14].

Wind towers can easily be incorporated in low-rise buildings. It may be noted that wind towers may need to be shut off when cooling is not required, and hence, such provisions may be included in the design. Due consideration must also be given to prevent the entry of dust, birds and insects.

3.4.1.3 Induced Ventilation

Passive cooling by induced ventilation can be very effective in hot and humid climates as well as hot and dry climates. This method involves the heating of air in a restricted area through solar radiation, thus creating a temperature difference and causing air movements. The draft causes hot air to rise and escape to the ambient, drawing in cooler air and thereby causing cooling. In effect, a solar chimney is created to cause continuous air circulation. Figure 3.27 illustrates the principle of induced ventilation and some of its variations.



Variations and controls:

Arrangements may be made to draw air from the coolest part of the structure as replacement, to set up a continuous circulation and cool the living spaces. Curved roofs and vents are used in combination for passive cooling of air in hot and dry climates, where dusty winds make wind towers impracticable. The system works on the principle of cooling by induced ventilation, caused by pressure differences.

This principle is illustrated in Fig. 3.28. Wind flowing over a curved surface creates a pressure difference across it. If vents are provided on the surface, air is sucked out of the structure through the openings. Therefore, the hot internal air forces its way out through the vents inducing air-circulation. Air vents are usually placed above living rooms.



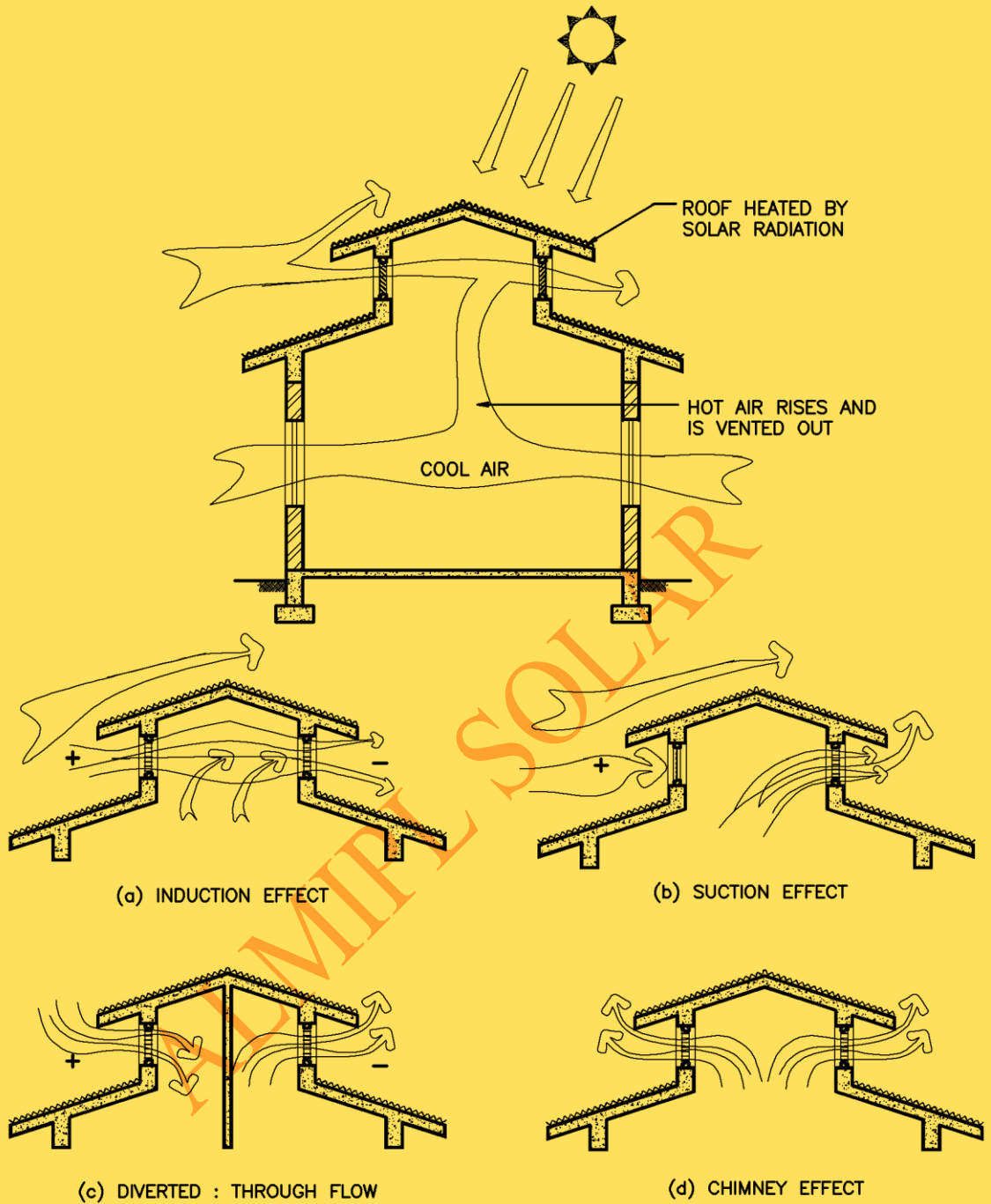

Fig. 3.27 Induced ventilation: principle and variations

4th Floor 4B, Mandira Apartments,
 North Boag Road, T-Nagar Chennai- 600 017
 Email: Solarbazaarpl@gmail.com
 Web: www.almipl.com
 Mobile: 94452 30332 / 9383132332

Green Energy Promoters



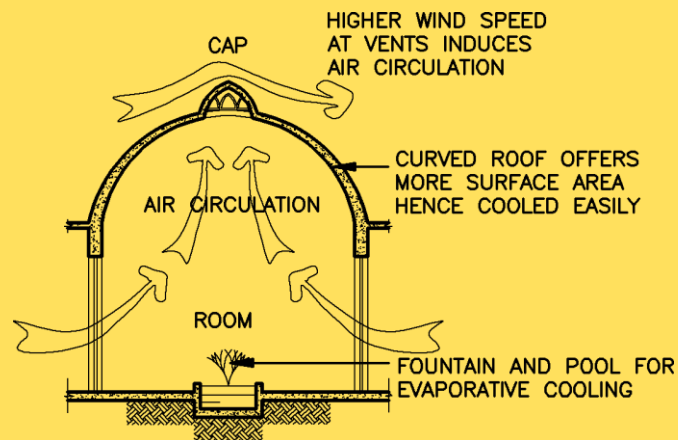

Fig. 3.28 Section showing induced ventilation through curved roof and air vents

The cooling effect can be enhanced by providing evaporative cooling. A pool of water is usually kept on the floor directly below the vents so that the air flowing into the room gets cooled, in turn cooling the living space. The air vents are usually provided with protective caps which help to direct the winds across them.

3.4.1.4 Nocturnal Cooling

Buildings may be cooled indirectly by ventilating at night, if the ambient air is cooler than the room air. This cools the interior mass of the building and on the following day, the cooled mass reduces the rate of indoor temperature rise and thus provides a cooling effect. This strategy is termed as nocturnal ventilative cooling.

Because buildings are usually occupied during the day, nocturnal ventilative cooling can be effective only to the extent that it can lower indoor temperatures the following day.



It is particularly important that the indoor maximum temperature the next day be lowered. Such lower indoor temperatures can be achieved only if the building is kept closed and unventilated during the daytime hours. In this respect, daytime comfort ventilation and nocturnal cooling are mutually exclusive. At any given place on any given day, one or the other should be considered as the best approach to provide daytime comfort.

There are several design options to provide the thermal mass that will serve as the nocturnal cold storage:

- structural mass of the building such as walls, partitions, floors, etc., cooled by whole space ventilation
- embedded air spaces (passages) within floors, ceilings and/ or walls through which outdoor air is circulated
- specialised storage such as a rock bed or a water tank with embedded air tubes, cooled at night by outdoor air

The applicability of nocturnal ventilation cooling is limited to a certain range of conditions. Limitations on applicability are posed on the one hand by climatic conditions, and on the other by the comfort and functional needs of occupants.

These limitations particularly affect the decision to leave windows open throughout the night to obtain effective nocturnal ventilation cooling.



3.4.2 Evaporative cooling

Evaporative cooling is a passive cooling technique in which outdoor air is cooled by evaporating water before it is introduced in the building. Its physical principle lies in the fact that the sensible heat of air is used to evaporate water, thus cooling the air, which in turn cools the living space in the building. Evaporation occurs at the water-air interface. An increase in the proportion of the contact area between water and air enhances the rate of evaporation and thereby the potential for cooling. The presence of a waterbody such as a pond, lake or sea near the building, or a fountain in the courtyard can provide a cooling effect. Cisterns or wetted surfaces can also be placed in the incoming ventilation stream. Such direct systems typically use little or no auxiliary power, are simple and can avoid the need for large surfaces of water and movement of large volumes of air. They are, therefore, particularly suited to hot and dry regions.

The airflow in these systems can be induced mechanically or passively - for example, evaporative cooling towers that humidify the ambient air can be used. This is direct evaporative cooling. The main disadvantage of direct systems is in the increased moisture content of the ventilation air supplied to the indoor spaces. High evaporation may result in discomfort due to high humidity.



However, passive evaporative cooling can also be indirect [?] the roof can be cooled with a pond, wetted pads or spray, and the ceiling transformed into a cooling element that cools the space below by convection and radiation without raising the indoor humidity [14].

The efficiency of the evaporation process depends on the temperatures of the air and water, the vapour content of the air, and the rate of airflow past the water surface. The provision of shading and the supply of cool, dry air will enhance evaporation. A comprehensive discussion on evaporation has been reported by Bansal et al. [11]. The most commonly used evaporative cooling system in north India is the desert cooler consisting of water, evaporative pads, a fan and a pump. It is a hybrid type of direct evaporative cooling system [17].

Watt [18] has proposed the following guidelines for using evaporative cooling:

- Direct evaporative coolers should have an average saturation efficiency of 70% or more, and the cooled air should enter the indoor space without any additional heat gain.
- The maximum indoor air velocity induced by the cooled air must be 1 m/s.
- The room temperature should be reduced by at least 3°C before the cool air is discharged out of the room.
- The temperature of the cooled space should be about 4 °C below the outdoor dry bulb temperature. This is necessary to counteract the incoming radiant heat.



On a psychrometric chart, evaporation is characterized by a displacement along a constant wet bulb line, AB in Fig. 3.29 [19]. When the decrease in the dry bulb temperature is accompanied by an increase in the moisture content of the air, the process is commonly referred to as 'direct evaporative cooling'. The passive downdraft evaporative cooling system is an example of this process. When the evaporation of water takes place on a surface, or inside a tube, resulting in a decrease of surface temperatures, it is possible to cool air adjacent to these surfaces without increasing its moisture content. In this case, the process is referred to as 'indirect evaporative cooling' and is characterized by a displacement along a constant moisture content line CD shown in Fig. 3.29. An example of this is the roof surface evaporative cooling system. These techniques are discussed in detail in the following sections.

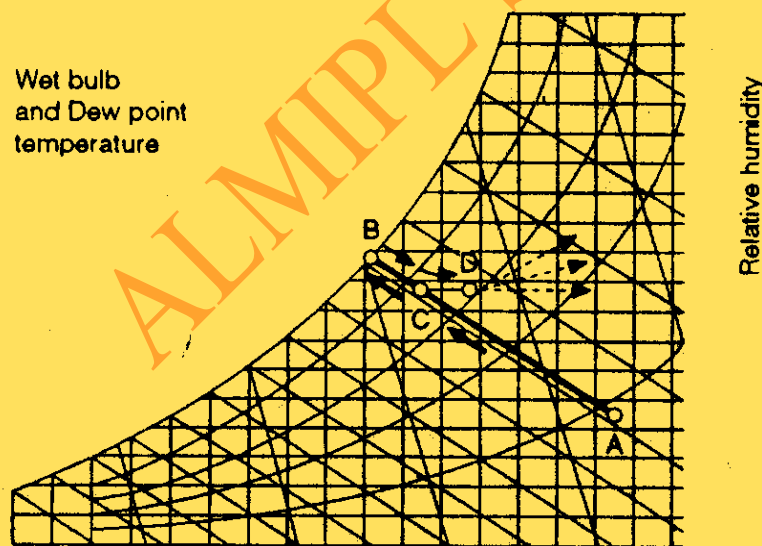

Fig. 3.29 Psychometric chart showing evaporative cooling

3.4.2.1 Passive Downdraft Evaporative Cooling (PDEC)

Evaporative cooling was extensively used in the vernacular architecture of Pakistan, Iran, Turkey and Egypt. Wind catchers called 'malqafs' captured wind and directed it over porous water pots, thus cooling the air as a result of latent heat of vaporisation. This system maintained a balance between two important parameters of passive cooling - thermal performance and ventilation effectiveness.

Contemporary passive downdraft evaporative cooling systems consist of a downdraft tower with wetted cellulose pads at the top of the tower. Water is distributed on the top of the pads, collected at the bottom into a sump and recirculated by a pump. Certain designs exclude the re-circulation pump and use the pressure in the supply water line to periodically surge water over the pads, eliminating the requirement for any electrical energy input. In some designs, water is sprayed using micronisers or nozzles in place of pads, in others, water is made to drip. Thus, the towers are equipped with evaporative cooling devices at the top to provide cool air by gravity flow. These towers are often described as reverse chimneys. While the column of warm air rises in a chimney, in this case the column of cool air falls.



The air flow rate depends on the efficiency of the evaporative cooling device, tower height and cross section, as well as the resistance to air flow in the cooling device, tower and structure (if any) into which it discharges. [20]

This system depends on two basic factors that determine its effectiveness: (1) amount of cooling of the ambient air achieved, and (2) the rate at which this conditioned ambient air replaces the stale air within the building. The former can be easily achieved by increased air- water contact zone. This factor usually dictates the height of the tower and in turn, influences the massing of the building design. The second factor, however, requires a complex interplay of different variables to achieve an effective performance. These variables dictate the configuration of the tower termination, the positioning of multiple towers within the building, the circulation pattern within the building, and even the configuration of openings between adjacent spaces served by these towers [14].

The temperature of the incoming ambient air drops while crossing the pads. Therefore, the height of the tower and the area of the wetted pads are not expected to have any appreciable effect on the temperature of the air in the tower in a given combination of ambient dry and wet bulb temperatures. However, these two system design factors affect the airflow rate, and hence the total cooling effect generated by the system [14].



Performance Analysis

PDEC systems have been used with various types of cooling devices such as, spray devices (pressure and ultrasonic nozzles), aspen fibre pads, corrugated cellulose pads, etc. The performance analysis would thus vary depending on the evaporating cooling facilities provided in the tower. Aspen pads cause a high pressure drop relative to sprays and corrugated media, but they are low in cost. Spray devices may require efficient mist eliminators for removing fine droplets from the air because mist impedes air flow [20].

Givoni [21] has proposed a semiempirical model to estimate exit air temperature and flow rate of a PDEC tower. The tower uses vertical wetted cellulose pads called CELdek. Water is distributed at the top of the pads, collected at the bottom into a sump, and is re-circulated using a pump.



The exit air temperature (T_{exit}) is given by

$$T_{exit} = T_{db} + \frac{0.87(T_{db} - T_{wb})}{0.3 + v_w} \quad (3.1)$$

where T_{db} = dry bulb temperature of ambient air ($^{\circ}\text{C}$)

T_{wb} = wet bulb temperature of ambient air ($^{\circ}\text{C}$)

v_w = wind speed (m/s)

The flow rate of air can be estimated from

$$m_{air} = 0.03A_{wpad} \sqrt{H} (T_{db} - T_{wb}) \quad (3.2)$$

and exit air speed is given by

$$v_{air} = \frac{m_{air}}{A_{tower}} \quad (3.3)$$

where,

m_{air} = tower's air flow rate (m^3/s)

A_{wpad} = area of the wetted pads (m^2)

H = height of the tower (m)

A_{tower} = cross sectional area of the tower (m^2)

These equations can be applied mainly as a tool in the initial design stages [21].

Givoni [22] has developed performance equations for the “shower” tower. It consists of an open shaft with showers at the top and collecting “pond” at the bottom. The water collected at the bottom of the pond is recirculated by a small pump. When drops of water are sprayed vertically downward from the top of the shaft, they entrain a volume of air which flows down the shaft with falling water. The air thus gets cooled and can be used for cooling of a building. The shaft should be installed adjacent to an opening of the building and kept open to the outdoor air. The system can use even brackish or sea water since evaporation takes place in the free air stream.

The exit air temperature is given by

$$T_{exit} = T_{db} - 0.9 * (T_{db} - T_{wb}) * [1 - e^{-1.5 * H}] * [1 - e^{-0.15 m_{water}}] \quad (3.4)$$

m_{water} = water flow rate (litres/minute)

The flow rate of air is given by

$$m_{air} = 7 m_{water} \sqrt{H} / 600 \quad (3.5)$$

These relations are valid for a particular type of shower. Givoni [22] has compared the performance of the “shower” tower under the three different climatic conditions, namely, Riyadh (Saudi Arabia), Los Angeles (USA) and Yokohama (Japan). He has demonstrated that the system can provide effective cooling in all these climates and the relations are validated through measurements.

Example:

Passive downdraft evaporative cooling tower has been used successfully at the Torrent Research Centre in Ahmadabad. The inside temperatures of 29 - 30 °C were recorded when the outside temperatures were 43 - 44 °C. Six to nine air changes per hour were achieved on different floors [13].



3.4.2.2 Roof Surface Evaporative Cooling (RSEC)

In a tropical country like India, the solar radiation incident on roofs is very high in summer, leading to overheating of rooms below them. Roof surfaces can be effectively and inexpensively cooled by spraying water over suitable water-retentive materials (e.g., gunny bags) spread over the roof surface. As the water evaporates, it draws most of the required latent heat from the surface, thus lowering its temperature and reducing heat gain. Besides, evaporation also cools the air above the roof. The cool air slides down and enters the living space through infiltration and ventilation, providing additional cooling. This is an example of the passive indirect evaporative cooling technique.

ALMIPLE



A critical factor determining the performance of a RSEC system is the sustained wetness of the roof surface. The surfaces may be sprayed intermittently, as it is only necessary to keep them moist. Evaporation of the water from a roof pond (a large mass of water stored on the roof) can also be used for reducing the cooling load in summer. However, to use this cooling technique, the roof has to be made structurally strong and waterproof. Comparatively, cooling by sprinkling water is more advantageous as it provides a larger surface area for evaporation without the need for any storage.

For installing a roof surface evaporative cooling system, the following points need to be taken note of:

- 1) Suitable waterproofing treatment of the roof should be done.
- 2) The roof must be covered with water absorptive and retentive materials such as gunny bags, brick ballast, sintered fly-ash, coconut husk or coir matting. On account of their porosity, these materials when wet, behave like a free water surface for evaporation. The durability of such materials is rather good, but they have to be treated for fire safety.
- 3) During peak summer, the quantity of water needed is approximately 10 kg/ day/ m² of roof area.
- 4) The roof must be kept wet throughout the day using a water sprayer. The sprayer can be manually operated or controlled by an automatic moisture-sensing device. The sprayer usually works at low water pressure which can be achieved either by a water head of the storage tank on the roof, or by a small water pump.



For installing a roof surface evaporative cooling system, the following points need to be taken note of:

- 5) Suitable waterproofing treatment of the roof should be done.
- 6) The roof must be covered with water absorptive and retentive materials such as gunny bags, brick ballast, sintered fly-ash, coconut husk or coir matting. On account of their porosity, these materials when wet, behave like a free water surface for evaporation. The durability of such materials is rather good, but they have to be treated for fire safety.
- 7) During peak summer, the quantity of water needed is approximately 10 kg/ day/ m² of roof area.
- 8) The roof must be kept wet throughout the day using a water sprayer. The sprayer can be manually operated or controlled by an automatic moisture-sensing device. The sprayer usually works at low water pressure which can be achieved either by a water head of the storage tank on the roof, or by a small water pump.

Performance Analysis

The effectiveness of RSEC depends on:

- ambient air temperature and humidity
- intensity of solar radiation
- wetness of the roof surface
- roof type

The effect of evaporation increases when the air humidity is low and the air temperature as well as the intensity of solar radiation falling on the roof surface are high. A uniform and constant wetting of the roof surface is essential for continuous evaporation.



It should be noted that the roof needs to be adequately treated with water proofing material.

The evaporation of water causes cooling of the roof surface. This sets up a temperature gradient between the inside air and outside roof surface, resulting in loss of heat from the inside to outside. Thus, heat transfer through the roof is the dominant aspect in the overall performance of RSEC. Higher the rate of heat transfer, more effective is the RSEC. Consequently the RSEC system is most effective when the roof has a high thermal transmittance (U).

The equivalent temperature of the outer surface of the roof in the presence of RSEC can be calculated from [23]:

$$\theta_{eff} = \frac{\alpha I_g + 0.13h_c \gamma R_a T_a - 0.013h_c R (1-\gamma) \epsilon \Delta R_{to}}{h_o + 0.13h_c R} \quad (3.6)$$

where

α = absorptivity of the roof surface

I_g = global solar radiation on the roof surface (W/m²)

ALMIP SOLAR

4th Floor 4B, Mandira Apartments,
North Boag Road, T-Nagar Chennai- 600 017
Email: Solarbazaarpl@gmail.com
Web: www.almipl.com
Mobile: 94452 30332 / 9383132332

Green Energy Promoters



h_o = total heat transfer coefficient from roof's surface (W/m²-K)
 h_c = convective heat transfer coefficient from roof's surface (W/m²-K)
 γ = relative humidity of air
 ϵ = emittance of the roof surface
 ΔR = net exchange of long wavelength radiation between the roof surface and the sky (W/m²)
 R_1 & R_2 = coefficients of correlation between saturation vapour pressure and temperature (R_1 is in Pa/°C and R_2 is in Pa)
 T_a = ambient temperature (°C)

Kumar and Purohit [23] have investigated the performance of RSEC for various roof types under different climatic conditions. The basis of comparison for unconditioned buildings is the discomfort degree hours (DDH), defined as:

$$DDH = \sum_{month} \sum_{day} (T_R - T_C) \quad (3.7)$$

where T_R and T_C refer to the indoor air and set point temperatures respectively; the +

superscript means that only positive values are to be considered. In case of conditioned buildings, the authors have used the monthly cooling load for establishing the effectiveness of the RSEC system. Table 3.9 presents the percentage reduction of DDH by employing RSEC for a few roof types under New Delhi climatic conditions, and for a set point of 27°C for non-conditioned buildings. The table also presents the percentage reduction of the cooling load for the month of May for conditioned buildings under similar conditions. It is seen that the lower the U value of the roof, the lesser is the effect of the RSEC system.



Table 3.9 Percentage reduction of yearly DDH due to roof surface evaporative cooling [23]

Roof Type	U (W/m ² -K)	DDH reduction (%)	Monthly cooling load reduction (%)
RCC	4.29	55.0	52.2
RCC- mud phuska-tile	2.60	38.2	37.1
Insulation- RCC	1.10	19.2	18.9
RCC- lime concrete	2.76	39.9	38.7

DDH: Discomfort degree hours

Example:

A wet gunny bag system was installed at the Bharat Heavy Electricals Limited factory at Haridwar during the summer of 1979. The building over which the cooling system was tried, is a four-storeyed engineering building which has a large number of offices and rooms. A monitoring of the performance showed that a reduction of 17 °C and 8 °C was observed in the peak value of ceiling temperature and indoor air temperature respectively [17].

3.4.2.3 Direct Evaporative Cooling using Drip-type (Desert) Coolers

Desert coolers are very popular in the northern parts of India. They can cool large volumes of outside air through evaporation of water. This air is delivered to the indoors where it absorbs heat from walls, ceilings, furnishings and the occupants. The warm air is finally discharged to the outdoors.



where it absorbs heat from walls, ceilings, furnishings and the occupants. The warm air is finally discharged to the outdoors. Fresh outside air should be used rather than employing recirculation because, in the latter case, the wet bulb temperature continues to increase, resulting in unsatisfactory conditions. The cooler consists of a wetting pad, a water circulating pump, a fan, and a cabinet to hold these components. The water pump lifts the sump water up to a distributing system, from which it runs down through the pads and back into the sump. The wetting pad is usually made of aspen wood fibres and is fixed to the three sides of the coolers' walls in such a way that only air enters through the pads. A propeller-type fan or a centrifugal blower is used above the base of the cooler. The choice of the evaporating pad is a critical factor in determining the performance. The coolers are usually designed for a face velocity of 1 to 1.5 m/s with a pressure drop of about 30 N/m². In addition to providing cooling of the incoming air, the pads also act as air filters preventing the entry of particles having a size greater than 10 micrometers. The pads are chemically treated to prevent the growth of bacteria, fungi and other micro-organisms. When the cooler is used only for ventilating purposes, supplementary fibre glass filters are also used. It must be noted that the material used in the construction of the pump, sump, water-distribution system, and casing should necessarily be corrosion resistant.



3.4.3 Nocturnal Radiation Cooling

Nocturnal radiation cooling refers to cooling by exposure of any element of the external envelope of the building to a cool night sky. Warm objects directly exposed to the sky radiate their heat out to it at night. Heat loss occurs by emission of long wavelength radiation, and hence surfaces should ideally have high emissivity. The presence of clouds at night limit the amount of heat that can be radiated to the outer space, but on a clear night, the effective sky temperature can be significantly lower than the ambient air temperature. The heat accumulated during the day is lost by radiation to the cool night air, thereby cooling the envelope. The envelope thus acts as cold storage during the day, drawing the heat away from the living space. The method works efficiently in arid climates, where ambient temperatures in the night are significantly lower than the day temperatures. Nocturnal radiation cooling works without consuming any water, unlike evaporative cooling systems. Its operation is illustrated in Fig 3.30.

The roof, being the part exposed to the sky, is the most effective long wave radiator. The rate of heat exchange depends on the temperature difference between the emitting surface and the surrounding atmosphere. Regions with large diurnal temperature variations will have higher nocturnal radiation cooling. Vapour pressure and the presence of clouds in the sky also affect the heat exchange.



For effective radiant cooling, the thermal link between the emitting surface and the living space has to be good. Otherwise, the cooling resulting from radiation exchange will only serve to cool the ambient air, rather than the living space. The roof pond is an example of the concept of nocturnal radiation cooling. In this system, a mass of water is stored on the roof of the building. During summer days, the pond is protected and insulated by an external, movable and reflective insulation. The insulation prevents solar radiation from reaching the water mass and keeps it cool. The cool water then absorbs heat from the rooms below and cools the indoor air.

At night, the insulation is removed and the water cools by convection and radiation. The effectiveness of the roof pond may be gauged from the fact that an indoor temperature of 21°C can be maintained when the outside temperature is as high as 35°C [10].



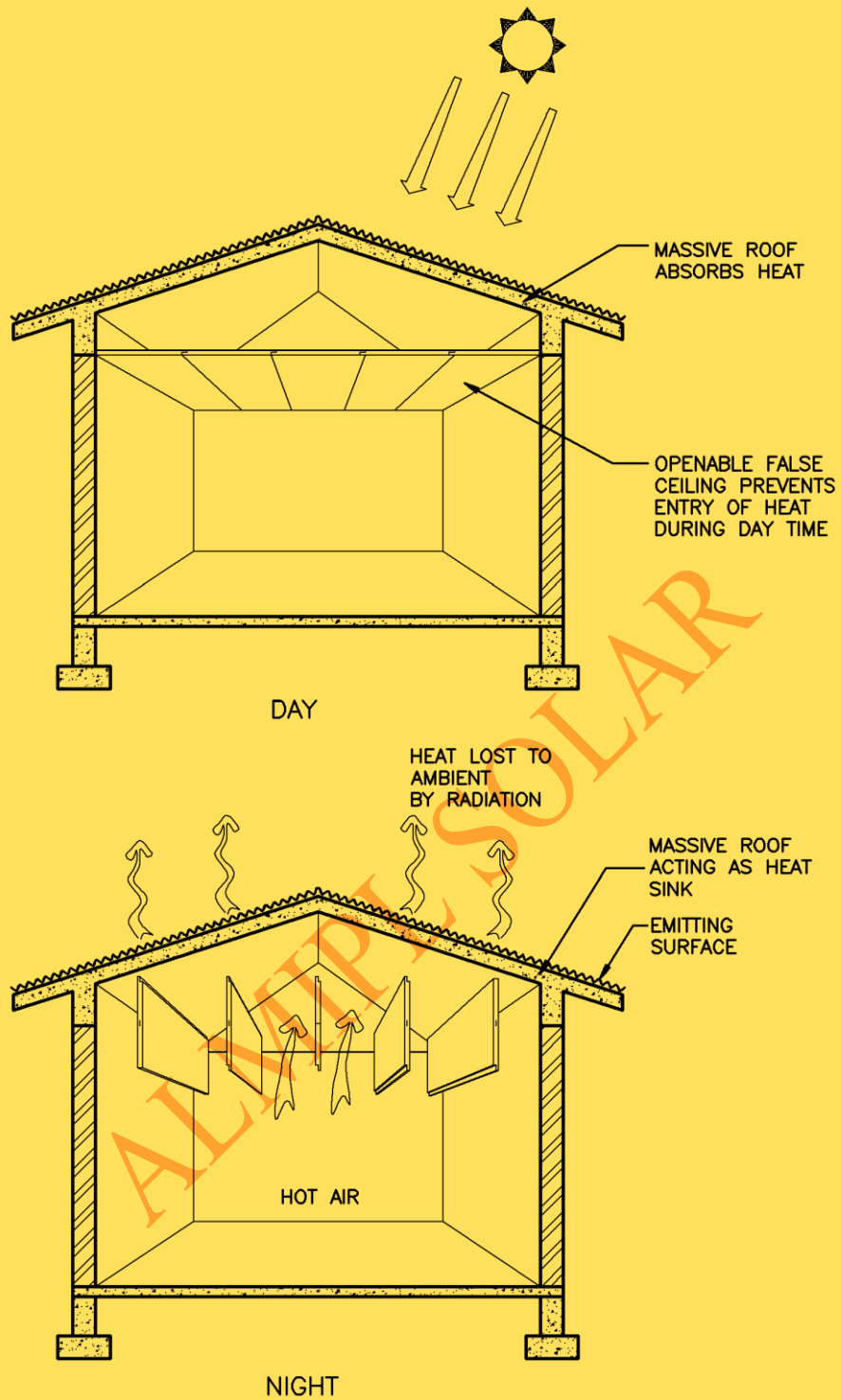

Fig. 3.30 Nocturnal radiation cooling: working principle



In winter, the panel positions are reversed. During the day, the insulation is removed so that heat is absorbed by water for heating the interior. At night, the insulation cover reduces the heat loss. The effectiveness of the roof pond in winter is no less than that in summer: the indoor temperature can be maintained at about 21°C while the outside is as low as -1.1°C [10]. The principles involved in this technique are schematically represented in Fig 3.31.

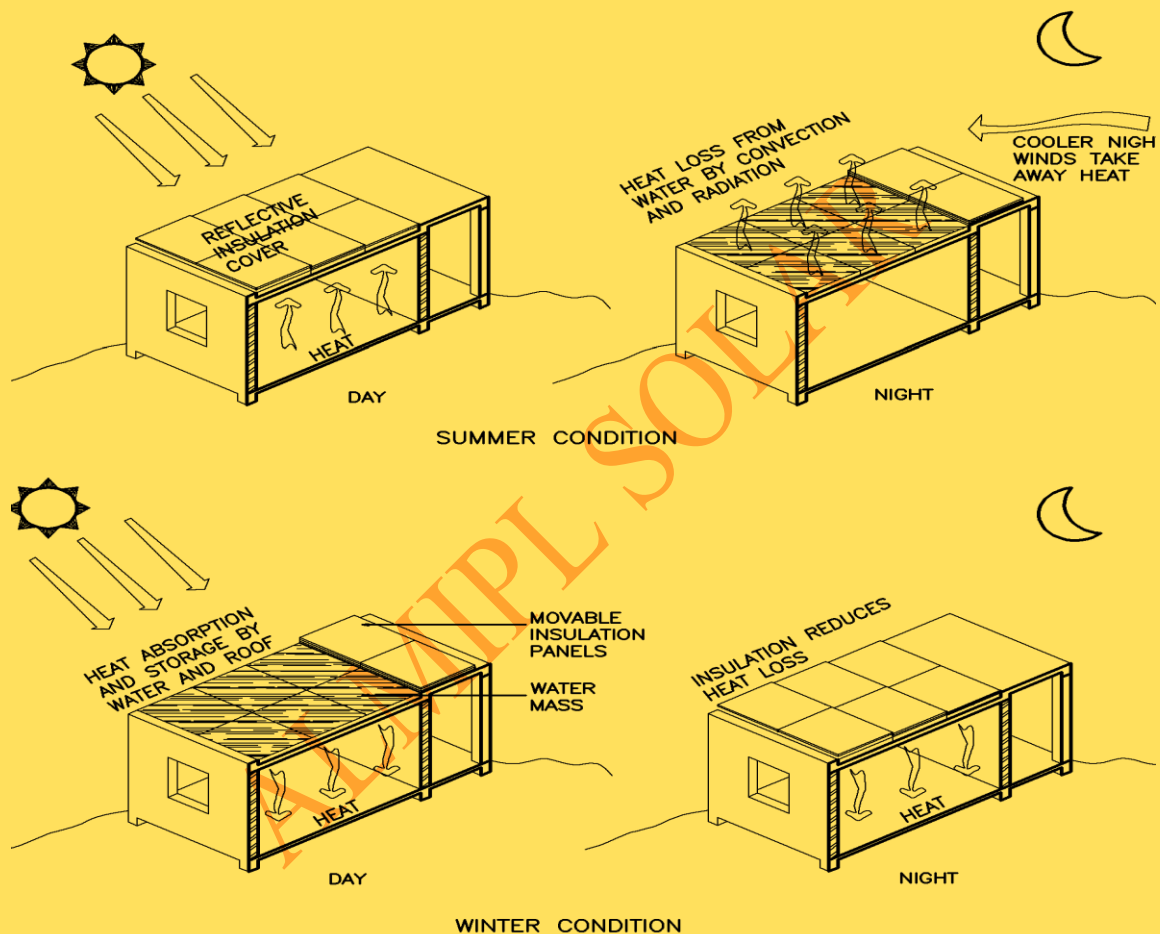

Fig. 3.31 Working principle of a roof pond



Water in transparent bags or in metal / fibreglass tanks is kept on the roof, the depth ranging from 150 to 300 mm. The top of the container/bag must be transparent to solar radiation whereas its bottom (inside surface) should be of a dark colour. If both sides of the container are transparent, then the top surface of the roof needs to be blackened for absorbing solar radiation. A clear top and black bottom helps in minimising temperature stratification in the pond water. Otherwise, hot water at the top would lose its heat to the exterior, and the cold water at the bottom would inhibit the heat transfer to the interior of the building. The movable insulation is usually of 50 mm thick polyurethane foam, reinforced with fibreglass strands and sandwiched between aluminium skins.

The water-proofing layer of the roof should not inhibit the heat transfer from the pond to the interior [10]. The details of a roof pond are shown in Fig. 3.32. Radiation is responsible for the thermal interaction between the roof and the living space. Therefore, the ceiling of the room must not be very high, as the intensity of the radiation reduces with height or distance. This technique is effective for one or two storeyed buildings.



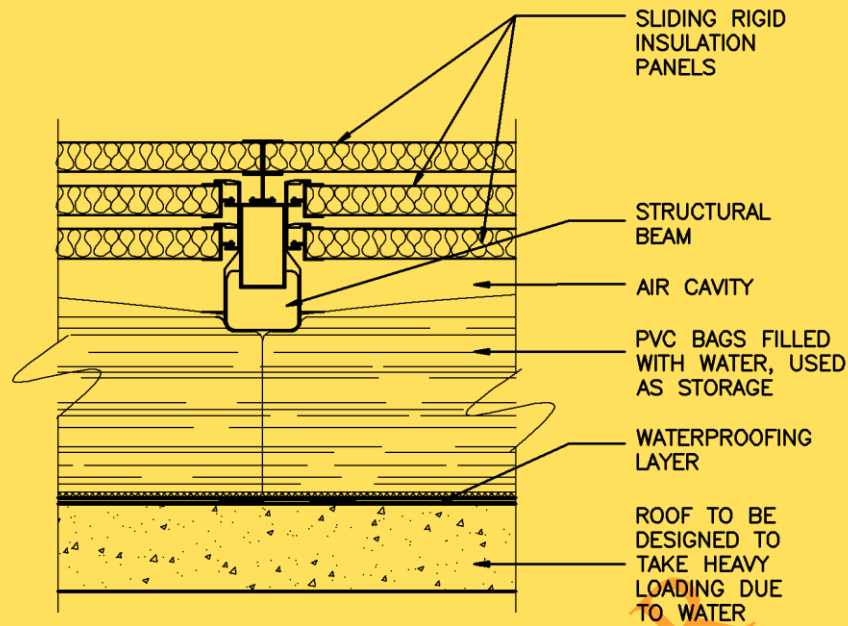

Fig. 3.32 Detail of a roof pond

Variations may be achieved by altering the ratios of heat transfer surfaces to thermal mass. The larger the storage volume, the greater and longer the heat storage. Smaller containers provide greater heat exchange as the surface area increases, resulting in faster distribution. During winter, a transparent cover may be provided over the water bags, leaving a gap. Air is blown through these gaps, forming an insulation cover to reduce heat loss. During summer the gaps are flooded with water and the transparent cover is removed.

Another way of using nocturnal radiation cooling is to expose lightweight radiators to the night sky. Through these radiators, a fluid is circulated which gets cooled. The cooled fluid can be used to cool a thermal storage system at night. The cold storage can be used the following day for space cooling.



Radiative cooling is effective in the hot and dry climate where nights are clear. In the case of humid atmosphere, condensation may occur on the radiating surface due to a decrease in its temperature to below dew point. The condensate transfers the latent heat of vaporisation to the surface, keeping it warm. As a result cooling is not achieved.

3.4.4 Desiccant Cooling

Desiccant cooling is effective in warm and humid climates. Natural cooling of human body through sweating does not occur in highly humid conditions. Therefore, a person's tolerance to high temperature is reduced and it becomes desirable to decrease the humidity level. In the desiccant cooling method, desiccant salts or mechanical dehumidifiers are used to reduce humidity in the atmosphere. Materials having high affinity for water are used for dehumidification. They can be solid like silica gel, alumina gel and activated alumina, or liquids like triethylene glycol. Air from the outside enters the unit containing desiccants and is dried adiabatically before entering the living space. The desiccants are regenerated by solar energy. Sometimes, desiccant cooling is employed in conjunction with evaporative cooling, which adjusts the temperature of air to the required comfort level.



3.4.4 Earth Coupling

This technique is used for both passive cooling as well as heating of buildings, a feat which is made possible by the earth acting as a massive heat sink. The temperature of the earth's surface is controlled by the ambient conditions. However, the daily as well as seasonal variations of the temperature reduce rapidly with increasing depth from the earth's surface. At depths beyond 4 to 5m, both daily and seasonal fluctuations die out and the soil temperature remains almost stable throughout the year. It is equal to the annual average ambient air temperature at that place. The temperature of the soil at depths beyond 4 to 5m can however be modified by suitable treatment of the earth's surface. For increasing the temperature, the earth's surface can be blackened/ glazed, and for decreasing its value the surface can be shaded, painted white, wetted with water spray or can have thick vegetation. Thus, the underground or partially sunk buildings would provide both cooling (in summer) and heating (in winter) to the living space. Besides, load fluctuations are reduced by the addition of earth mass to the thermal mass of the building. The infiltration of air from outside is reduced, and there is a decrease in noise and storm effects. An earth-sheltered structure has to be heavier and stronger to be able to withstand the load of the earth and the vegetation above. Besides, it should be suitably waterproofed and insulated to avoid ground moisture. For this, a high level of design and supervision in construction is required.



A building may be coupled with the earth by burying it underground or berming. Figure 3.33 shows an example of earth berming. Another possibility of utilising the ground effect is through earth-air pipe systems, and is discussed in the following section.

3.4.4.1 Earth-air pipe system

The earth-air pipe system consists of a pipe of appropriate dimensions buried at a depth of about 4 to 5m in the ground. Ambient air is blown through it by a blower at one end of the pipe. The other end is connected to the building to which it supplies conditioned air. Figure 3.34 shows the schematic of such a system. As explained earlier, the temperature at a depth of about 4 to 5m is very stable and is equal to the annual average ambient temperature. It remains unaffected even if heat is withdrawn from or supplied to the ground, due to its large thermal capacity. The earth-air pipe system takes advantages of this fact.

Ambient air flowing through the pipe gets cooled (in summer) or heated up (in winter) before entering the living space of a building. If the pipe is of adequate length (for a given air flow rate), the desired heating or cooling effect can be realised



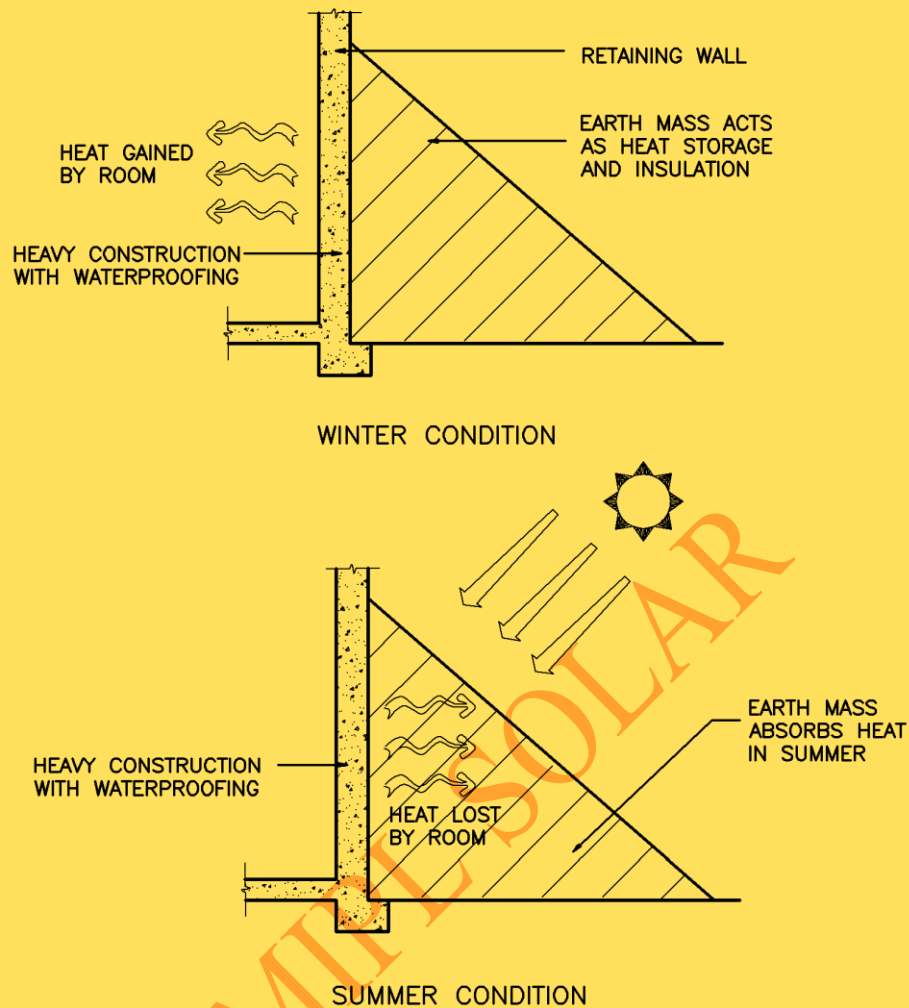

Fig. 3.33 Working principle of earth-berming

To meet the thermal load requirement of the building, one may use more than one pipe buried at the same depth a few meters apart. However, it is possible for the relative humidity of the air from the earth-air pipe system to be higher than the ambient humidity, depending on the soil conditions. If the air fed to living spaces is not reused, the system is called single pass system. The earth-air pipe system can also be used in the re-circulation mode.



In that case air from the living space is re-circulated through earth-air pipe and is supplied back to the living space.

By using an earth-air pipe system, energy and peak load requirements for space conditioning of a building can be significantly reduced. This would lead to energy conservation. The use of such systems has gained increasing acceptance during the last few years, and a number of them are being installed in India, China, USA and Europe.

ALMIPL SOLAR

4th Floor 4B, Mandira Apartments,
North Boag Road, T-Nagar Chennai- 600 017
Email: Solarbazaarpl@gmail.com
Web: www.almipl.com
Mobile: 94452 30332 / 9383132332

Green Energy Promoters



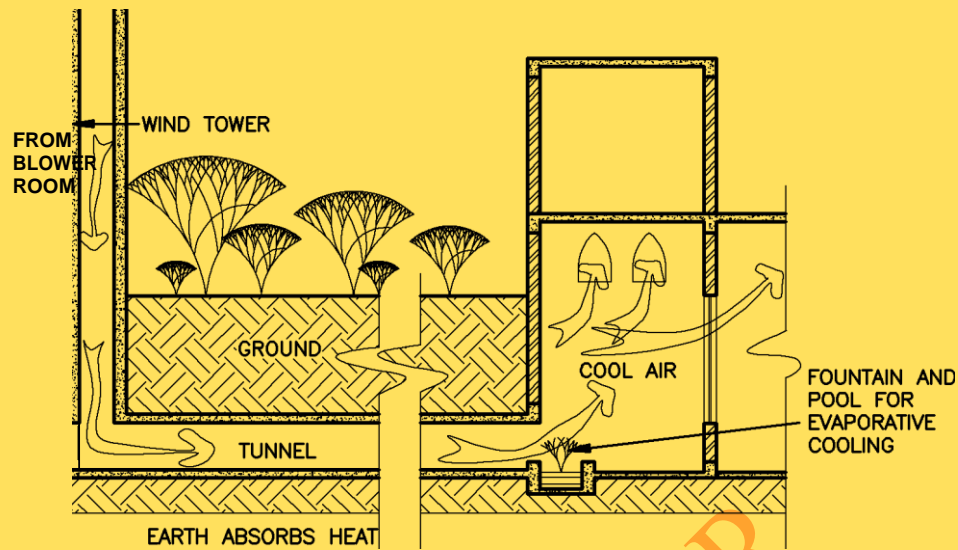

Fig. 3.34 Earth-air pipe system: working principle

Performance Analysis

The performance of the earth-air pipe system depends on the rate of heat transfer between the air and surrounding earth, which in turn is governed by the resistances offered by: (i) the convection between air and inner surface of the pipe, (ii) conduction through the thickness of the pipe wall, and (iii) conduction through the surrounding earth. Thus, the performance of the earth-air pipe system depends on [24,25]:



- system parameters (depth of the pipe from the earth's surface, its length and radius, thermal conductivity of the pipe material, and air speed through the pipe)
- soil parameters surrounding the pipe (thermal conductivity, specific heat, density and moisture content)
- weather conditions (solar radiation, ambient temperature)
- earth's surface conditions (shaded, blackened, white-painted or wetted with water)

The longest resistance to the heat flow is due to the soil surrounding the pipe, and it is the main factor in controlling the rate of cooling/heating of the air in the pipe. Soil having higher thermal conductivity is desirable, and so wet soil is more effective in heat transfer. Resistance to the heat flow due to pipe material is comparatively very less, hence pipe thickness and its material is of little consequence to the process. The configuration (cross section and thickness) and material of the pipe is decided purely on the basis of cost considerations. Thus, a duct made of brick/stone or a concrete pipe will be almost as effective as a copper pipe.

The temperature T_{AL} at the end of a pipe of length L can be written as [24,25]:

$$T_{AL} = T_{EO} + (T_{AO} - T_{EO}) \exp\left[-\frac{L}{L_p}\right] \quad (3.8)$$

where,

$$L_p = m_a C_{PA} R_{th}; \quad m_a = \pi R_{ip}^2 v_A \rho_A$$

$$R_{th} = \frac{1}{2\pi R_{ip} h_i} + \frac{\ln\left(\frac{R_{op}}{R_{ip}}\right)}{2\pi k_p} + \frac{\ln\left(\frac{Z}{R_{op}} + \sqrt{\left(\frac{Z}{R_{op}}\right)^2 - 1}\right)}{2\pi k_g}$$

$$T_{EO} = T_{EM} + (T_{E \max} - T_{EM}) \exp\left[-Z \xi\right] \cos\left[\frac{2\pi}{t_y} (t - Z \xi)\right]$$

$$\xi = \sqrt{\frac{t_y k_g}{\pi \rho_g C_{pg}}}$$

$$T_{AO} = T_{AM} + (T_{AMax} - T_{AM}) \cos\left[\frac{2\pi t'}{t_h}\right] \quad (3.9)$$

C_{PA} = specific heat of air (J/kg-K)

C_{pg} = specific heat of the soil (J/kg-K)

h_i = connective heat transfer coefficient for the inner surface of the pipe to air (W/m²-K) k_g = thermal conductivity of the soil (W/m-K)

k_p = thermal conductivity of pipe material (W/m-K)

R_{ip} = pipe inner radius (m)

R_{op} = pipe outer radius (m)

t = time (zero on the day when $T_{E \max}$ occurs) (s)

t' = time (measured from the time when maximum temperature of the day occurs) (s)

t_h = duration of the day (24 x 3600 s = 86400 s)

t_y = time duration of a year in seconds (365 x 24 x 3600s = 31.5 x 10⁶ s)

T_{EM} = annual mean ambient air temperature (°C)

$T_{E \max}$ = maximum of the daily mean temperature of the year (°C)

T_{AM} = daily mean ambient air temperature (°C) $T_{A \max}$ = maximum

temperature of the day (°C) v_A = air

flow velocity (m/s)

Z = pipe depth (m)

ρ_g = density of the soil (kg/m³)

ρ_A = air density (kg/m³)

It is seen that the temperature of air at the end of the pipe depends on pipe parameters, air parameters and soil parameters.

The hourly cooling potential Q_c (in kWh), and heating potential Q_h (in kWh) can be calculated from the relations:

$$Q_c = \dot{m}_A C_{PA} (T_{AO} - T_{AL}) \quad (3.10)$$

$$Q_h = \dot{m}_A C_{PA} (T_{AL} - T_{AO}) \quad (3.11)$$

The performance of an earth-air pipe system has been estimated for Delhi climate conditions. For the weather data of June (summer) and January (winter), T_{AL} and Q_c are

calculated for various soil and systems parameters. The values of air properties and other quantities used in the calculations are:

$$\rho_A = 1.17 \text{ kg/m}^3, C_{PA} = 1000 \text{ J/kg-K}; k_A = 0.0265 \text{ W/m-K};$$

$t = 0$ in June and 302400 s in January; $T_{Emax} = 34.2^\circ\text{C}$ in June and 13.6°C in January; $T_{AO} = 38.5^\circ\text{C}$ in June and 8.5°C in January; $T_{EM} = 24.9^\circ\text{C}$; Friction factor = 0.08

Table 3.10 presents results for summer conditions in New Delhi. It is seen from the table that T_{AL} decreases as depth of the pipe (Z) increases.

The cooling potential also increases. Variations of T_{AL} is significant for low values of Z. After a depth of 5m, it hardly changes. Similarly the effectiveness of the earth-air pipe system improves when the pipe length (L), thermal conductivity of the soil (k_g), as well as that of the pipe (k_p) increase. The performance decreases with increase in pipe radius (R), pipe thickness [R_{op} & R_{ip}], and velocity [v_A] of the air in the pipe. While the effects of Z, L, R, v_A and k_g are quite significant, the effects due to k_p and thickness of the pipe are insignificant.



Table 3.11 shows similar effects for winter conditions in New Delhi. The results demonstrate the effect of various parameters from the point of view of designing an earth-air pipe system.

Example:

Earth-air pipe systems have been installed at many places in the country. RETREAT building, Gwalpahari, Gurgaon; Dera Library, Radha Swami Satsang, Beas, Dilwara Bagh; Country House of Reena and Ravi Nath, Wazirpur, Gurgaon[13], etc. use this system to name a few.

ALMIPL SOLAR

4th Floor 4B, Mandira Apartments,
North Boag Road, T-Nagar Chennai- 600 017
Email: Solarbazaarpl@gmail.com
Web: www.almipl.com
Mobile: 94452 30332 / 9383132332

Green Energy Promoters



Table 3.10 Variation of delivery temperature (T_{AL}) and cooling potential (Q_c) of an earth-air pipe system due to various system parameters for June conditions of New Delhi

Variable	Value	Delivery temperature T_{AL} ($^{\circ}C$)	Cooling potential Q_c (kWh)	Drop in temperature (Inlet - Delivery) ($^{\circ}C$)
Depth of pipe Z (m)	1	31.2	0.6	7.3
	3	27.5	0.9	11.0
	5	26.5	1.0	12.0
	7	26.7	1.0	11.8
Length of pipe L (m)	20	31.9	0.5	6.6
	40	28.4	0.8	10.1
	60	26.5	1.0	12.0
	80	25.5	1.1	13.0
Radius of pipe R (m)	$R_{ip.}= 0.075$; $R_{op}= 0.085$	24.4	0.3	14.1
	$R_{ip.}= 0.150$; $R_{op}= 0.160$	26.3	1.0	12.2
	$R_{ip.}= 0.225$; $R_{op}= 0.250$	29.8	2.1	8.7
	$R_{ip.}= 0.300$; $R_{op}= 0.325$	32.2	1.0	6.3
	$R_{ip.}= 0.150$; $R_{op}= 0.175$	26.5	1.0	12.0
	$R_{ip.}= 0.150$; $R_{op}= 0.190$	26.7	1.0	11.8
Air Velocity in pipe V_A (m/s)	1	26.5	1.7	12.0
	3	31.8	1.9	6.7
	5	34.0	2.0	4.5
	7	35.1	1.0	3.4
Conductivity of pipe k_p (W/m K)	0.2	27.3	0.9	11.2
	0.5	26.5	1.0	12.1
	1.0	26.3	1.0	12.2
	1.5	26.2	1.0	12.3
	3.0	26.1	1.0	12.4
	3.0	26.1	1.0	12.4
Conductivity of soil k_g (W/m K)	0.2	35.8	0.2	2.7
	0.6	31.9	0.5	6.6
	1.0	29.4	0.8	9.1
	1.5	27.5	0.9	11.0
	2.0	26.5	1.0	12.0
	3.0	25.8	1.0	12.7

R_{ip} =Internal diameter of pipe
 R_{op} =External diameter of pipe

The inlet air temperature is taken as 38.5 $^{\circ}C$ (i.e. monthly average maximum air temperature in June)



Table 3.11 Variation of delivery temperature (T_{AL}) and cooling potential (Q_c) of an earth-air pipe system due to various system parameters for January conditions of New Delhi

Variable	Value	Delivery temperature T_{AL} ($^{\circ}C$)	Heating potential Q_c (kWh)	Rise in temperature (Inlet - Delivery) ($^{\circ}C$)
Depth of pipe Z (m)	1	18.1	0.8	9.6
	3	21.0	1.0	12.5
	5	22.3	1.1	13.8
	7	22.5	1.2	14.0
Length of pipe L (m)	20	16.2	0.6	7.7
	40	20.2	1.0	11.7
	60	22.3	1.1	13.8
	80	23.5	1.2	15.0
Radius of pipe R (m)	$R_{ip.}= 0.075$; $R_{op}= 0.085$	24.7	0.3	16.2
	$R_{ip.}= 0.150$; $R_{op}= 0.160$	22.6	1.2	14.1
	$R_{ip.}= 0.225$; $R_{op}= 0.250$	18.6	1.9	10.1
	$R_{ip.}= 0.300$; $R_{op}= 0.325$	15.8	2.4	7.3
	$R_{ip.}= 0.150$; $R_{op}= 0.175$	22.3	1.1	13.8
	$R_{ip.}= 0.150$; $R_{op}= 0.190$	22.1	1.1	13.6
Air Velocity in pipe V_A (m/s)	1	22.3	1.1	13.8
	3	16.2	1.9	7.7
	5	13.7	2.2	5.2
	7	12.5	2.3	4.0
Conductivity of pipe k_p (W/m K)	0.2	21.5	1.1	13.0
	0.6	22.4	1.2	13.9
	1.0	22.6	1.2	14.1
	1.5	22.7	1.2	14.2
	3.0	22.8	1.2	14.3
Conductivity of soil k_g (W/m K)	0.2	11.8	0.3	3.3
	0.6	16.4	0.7	7.9
	1.0	19.3	0.9	10.8
	1.5	21.3	1.1	12.8
	3.0	22.9	1.2	14.4

R_{ip} =Internal diameter of pipe R_{op} =External diameter of pipe

The inlet air temperature is taken as 8.5 $^{\circ}C$ (i.e. monthly average maximum air temperature in January)

The earth-air pipe system is used to cool about 120 m² of floor area in the Dilwara Bagh house. Two rectangular pipes of cross sectional area of 0.6m x 0.8m, and a length of 60m are employed at a depth of 4m. A blower of 3 hp is used to force air into the system, and is housed in a blower room about 67.5m away from the house.

It maintains an air velocity of about 6m/s in the pipe, which is made of brick and sand stone. A cross-section of the pipe and a sketch plan of the system are shown in Figs. 3.35 and 3.36. The outlets of the system to the rooms are protected by earth-berms. A cross-section of the same is shown in Fig 3.37.

ALMIPL SOLAR



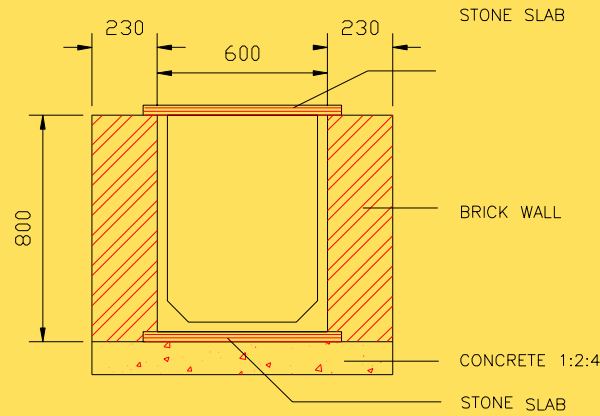

Fig. 3.35 Cross-section of pipe at the Dilwara Bagh House, Gurgaon

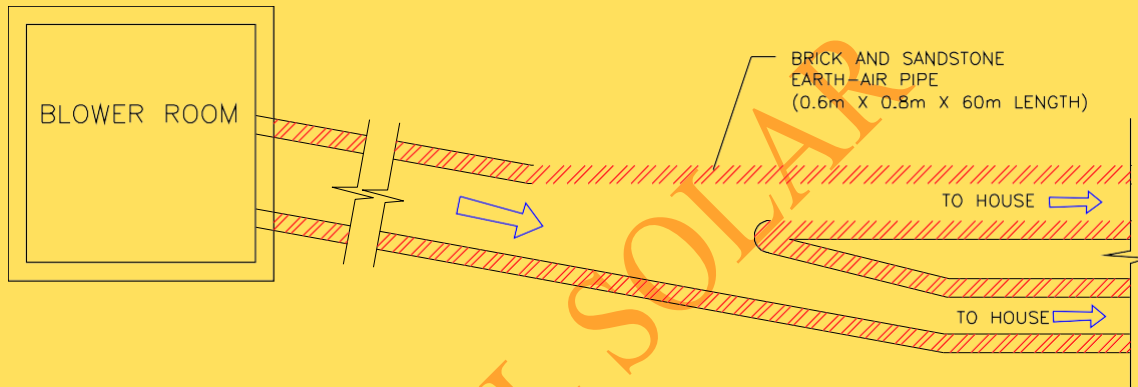

Fig. 3.36 Sketch plan of earth-air pipe system at the Dilwara Bagh House, Gurgaon

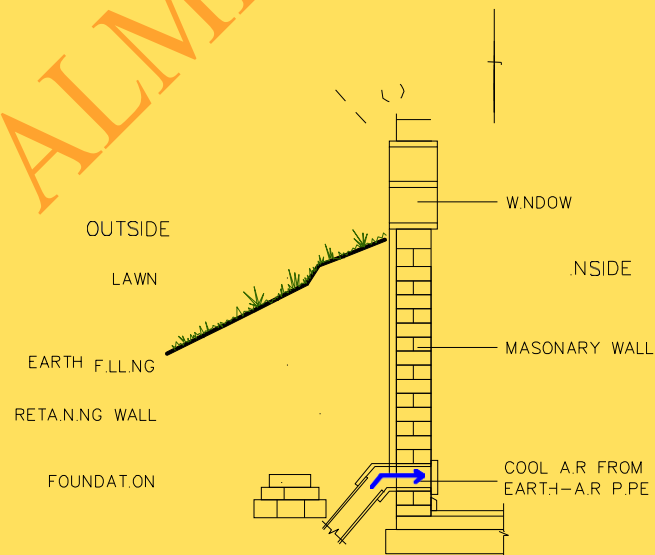

Fig. 3.37 Section showing earth berm at the Dilwara Bagh House, Gurgaon

Extensive post occupancy evaluation studies have been carried out by Thanu et al. [26]. Figure 3.38 shows a typical performance of the system during summer and winter conditions. It is seen that in summer, the exit or delivery temperature is about 29°C when outside can be as high as 38°C. Further, the fluctuation in room temperature is only 2.2°C as compared to 11.8°C for outside air. In winters, the delivery temperature is maintained at about 20°C, when outside air is about 8°C – an increase in temperature by about 12°C. Thus, the earth-air pipe system performs well both in summers as well as in winters. The system provides an average daily cooling potential of 242 kWh (thermal) in a summer month and about 365 kWh in a winter month. As the blower's power is 3 hp (2.2 kW), the coefficient of performance (COP) of the system is 4.5 in summer and 6.8 in winter.

TEMPERATURE (°C)
16
14

4th Floor 4B, Mandira Apartments,
North Boag Road, T-Nagar Chennai- 600 017
Email: Solarbazaarpl@gmail.com
Web: www.almipl.com
Mobile: 94452 30332 / 9383132332

Green Energy Promoters



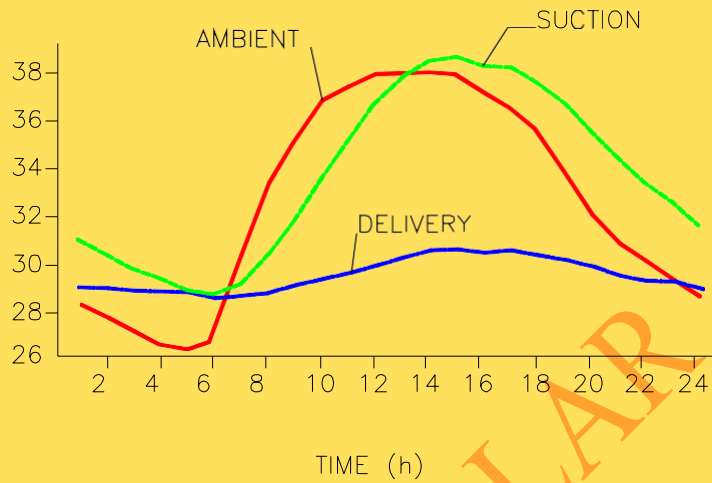

(a) Summer

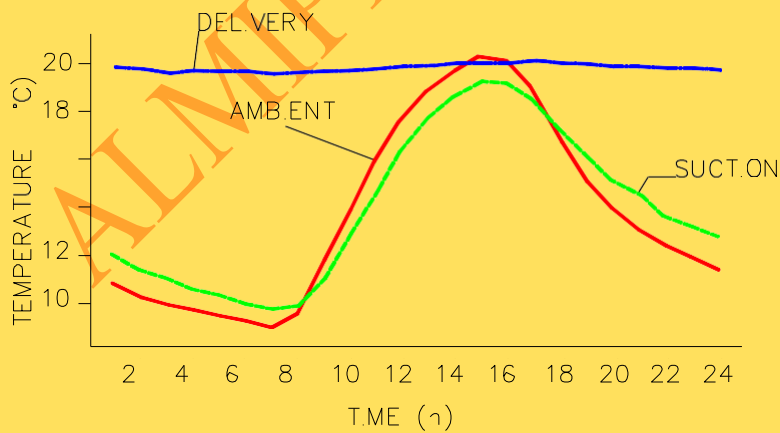

(b) Winter

Fig. 3.38 Typical performance of the earth-air pipe system



3.5 DAYLIGHTING

Vision is by far the most developed of all our senses and light has been the main prerequisite for sensing things. Light is that part of the electromagnetic radiation which is capable of exciting the retina of the eye to produce visual sensation. It is a vital and invaluable component of human life. Considerable care is therefore essential for creating effective visibility and providing visual satisfaction.

The visible spectrum, to which the human eye is sensitive, is a narrow band of wavelengths between 380 and 780 nm. Buildings must have sufficient lighting in this band. Light has a major effect on the way one perceives spaces and their functions. Sufficient light is required to carry out everyday tasks in homes, offices and factories. The illumination requirements for the comfortable performance of various tasks need to be suitably considered in design. For example, very bright lighting is required in a diamond polishing industry while soft lighting may be sufficient in a bedroom. The required illumination can be provided by daylight through windows and/ or by artificial light in the form of tubelights and lamps. In artificial lighting, the light source is under the user's control in the sense that the illumination level is independent of location, climate or even the construction of the building. On the other hand, daylighting strongly depends on external conditions and its control depends on the way a building is constructed. Very often, one finds numerous tubelights burning in offices, factories and homes during daytime even though there is plenty of sunlight outside.



Because of its variability and subtlety, natural light has a more pleasing effect than monotonous artificial lighting. Building components such as windows and skylights, which admit light, enable a visual communication with the outside world. Besides, plentiful daylight also has energy-saving implications. Since most buildings are largely used during the daytime, effective daylighting makes economic sense. Because a good daylighting system involves many elements, it is best to incorporate them in the building design at an early stage. The manner in which daylight enters and distributes itself in a room depends on the size and location of openings, type of glazing, configuration of the room, and reflective properties of walls, ceiling and other surfaces. The intensity of daylight and the daylight factor (explained under 3.5.1) also depend on the height and the location of the opening on a wall; the intensity reduces as the distance from the opening increases.

The pattern of artificial lighting in a building differs from climate to climate. For example, in hot and dry climates, internal shading devices are often used to protect the building from overheating by high solar radiation. This will drastically reduce the daylight entering the room, thereby increasing artificial lighting load. However, in cold and sunny climates shading devices are not required, so there is less need for artificial lighting. Correct daylighting design will reduce not only the energy cost but also the cooling cost, caused by lighting devices.



Under a European research programme, 60 buildings were monitored and documented from the point of view of daylighting. These case studies provide a valuable resource to building designers. Fontoynt [27] presents both quantitative as well as qualitative assessments of a range of daylighting solutions. The designing aspects of daylight systems in buildings have been explained by Baker and Steemers [28] in an accompanying publication.

3.4.5 Basic Principles of Daylighting

The ultimate source of daylight is the sun. By the time sunlight reaches the earth's surface, it has been subjected to atmospheric attenuation, scattering and reflection. The daylight received on the earth's surface is composed of direct light (light directly received from the sun) and diffuse light (light received from all parts of the sky due to atmospheric scattering and reflection). Light reaching a particular point inside a building may consist of, (1) **direct sunlight**, (2) **diffuse light or skylight**, (3) **externally reflected light** (by the ground or other buildings), and (4) **internally reflected light** from walls, ceiling and other internal surfaces [29,30]. This is depicted graphically in Fig. 3.39.



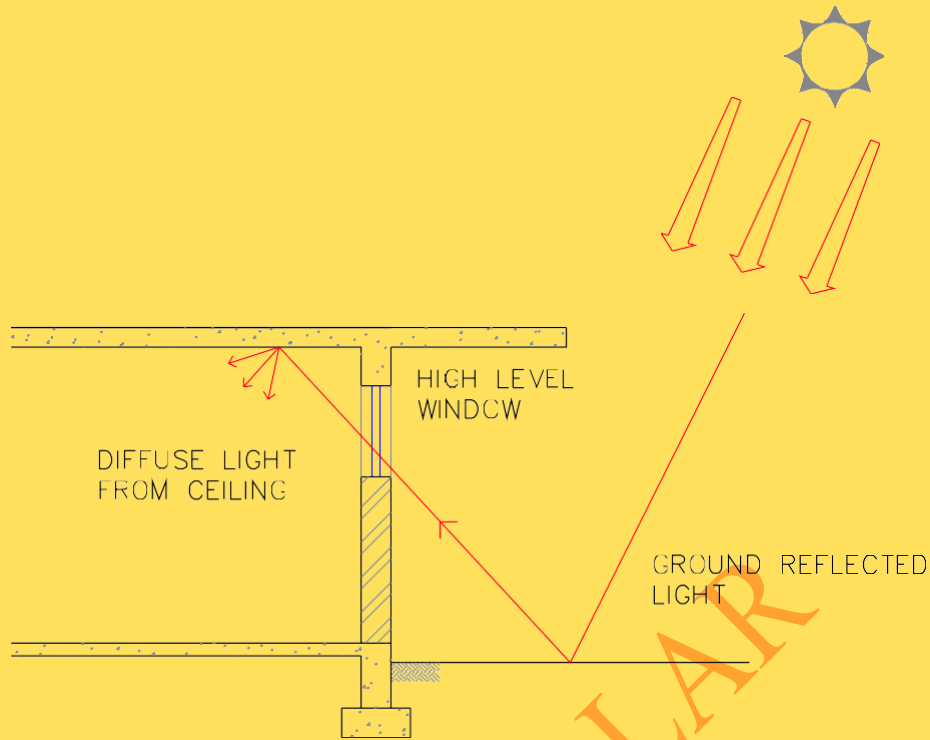

Fig. 3.39 Distribution of daylight

The availability of light within a building depends on its planform, orientation, the location and size of openings, characteristics of glazing, and internal reflections. Because of the variations in outdoor lighting levels, it is difficult (and perhaps meaningless) to calculate interior lighting in photometric illumination terms. However, inside a given building at a given point, the ratio of indoor illumination to the corresponding outdoor illumination can be taken as constant.



This constant ratio, expressed in percentage, is the daylight factor (DF), given by:

$$DF = \frac{E_i}{E_o} \times 100 \quad (3.12)$$

E_o

where,

E_i = indoor illumination at the point of consideration

E_o = outdoor illumination from unobstructed sky hemisphere

The three components contributing to daylight factor are: (a) sky component (SC), (b) externally reflected component (ERC), and (c) internally reflected component (IRC)

Thus,

$$DF = SC + ERC + IRC \quad (3.13)$$

Each component can be calculated by following standard procedures outlined in the BIS Handbook [5]. The magnitude of each of these components depends on design variables as follows:

Sky component (SC) - The area of sky visible from the point considered and its average altitude angle (luminance of the sky at that angle), window size and position in relation to the point, thickness of window frame, quality of glass and its clearness, and any external obstructions.



Externally reflected component (ERC) - The area of external surfaces visible from the point considered, and the reflectance of these surfaces.

Internally reflected component (IRC) - The size of the room, the ratio of surfaces (wall, roof, etc.) in relation to the window area, and reflectance of indoor surfaces.

Direct sunlight is excluded from the definition of daylight factor as it is not desirable from the perspective of the quality of the light. It creates problems of shadows and severe brightness imbalances that cause glare. Direct sunlight also brings excessive heat in summer. Adequate shading devices are therefore recommended not only for thermal comfort but also for visual comfort.

The outdoor illumination level E_o can be established for a given place by analysing the long-term illumination record. This is taken as 'design sky illumination' value. For India, it is taken as 8,000 lux for clear design sky [5].

For example, if $E_i = 300$ and $E_o = 8000$ lux, then,

$$DF = \frac{300}{8000} \times 100 = 3.75$$

(3.14)



Design variables such as window size can be manipulated to achieve this daylight factor. This method will ensure that 90% of the time, the inside illumination level is at the required level or exceeds it. For the remaining 10% of the time, one can rely on human adaptability. Recommended daylight factors for typical building interiors are presented in Table 3.12.

3.4.5 Daylighting Systems

The conventional modes of introducing daylight into the building include windows, clerestories, skylights (Fig. 3.40) and light shelves (Fig. 3.41). They can normally provide adequate daylight in the perimeter of buildings up to 5m of window or skylight. Light shelves are reflective horizontal surfaces that extend from the exterior to the interior of a building. They reflect sunlight onto the ceiling, which in turn reflects into the interior space. They can prevent unwanted direct sunlight, which is a source of glare, from entering the space.

Light shelves are intended to modify daylight distribution by reducing the sky component and increasing reflection from the ceiling resulting in a more uniform daylight distribution [27]. Reflective blinds offer good control of glare and solar protection. These also maintain



reasonable light levels inside, provided the ceiling is bright. One can use atria and courtyards, or use daylighting optical systems to deliver light to deeper parts of the building. Atria (Fig. 3.42) can help reduce heat losses, but their daylighting efficiency depends on the brightness of their walls and the shading on windows [27]. Daylighting optical systems require a collection system to gather and redirect the available light. This is then transmitted to the point of use inside the building and finally distributed as per the illumination requirement.

Table 3.12 Recommended daylight factors [10]

Building	Area/Activity	Daylight factor (%)
Dwellings	Kitchen	2.5
	Living room	0.625
	Study room	1.9
	Circulation	0.313
Schools	Class room	1.9 – 3.8
	Laboratory	2.5 - 3.8
Offices	General	1.9
	Drawing, typing	3.75
	Enquiry	0.625 – 1.9
Hospitals	General wards	1.25
	Pathology laboratory	2.5 – 3.75
Libraries	Stack room	0.9 – 1.9
	Reading room	1.9 – 3.75
	Counter area	2.5 – 3.75
	Catalogue room	1.9 – 2.5



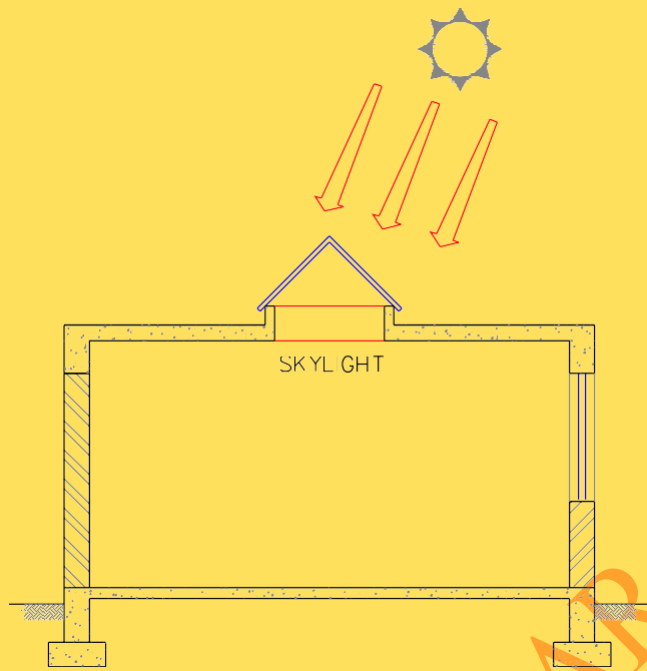

Fig. 3.40 Skylight

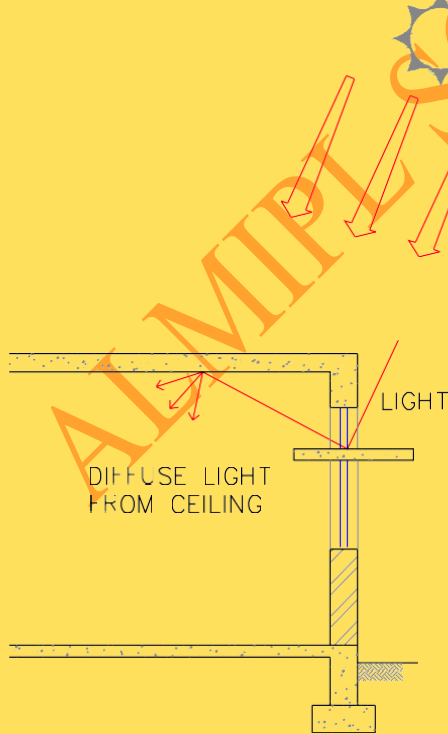

Fig. 3.41 Light shelf

SHELF

Certain systems capture and distribute light to the interiors using a pipe (Fig. 3.43) or lightwell (Fig. 3.44). These systems usually do not have any moving parts. Aluminium pipes with a clear acrylic dome on top and a translucent acrylic dome at the bottom are installed on the roof and used as sunpipes. The pipes are lined with silver to reduce reflection losses. The translucent dome at the bottom creates diffuse light in the living space. In reflective light guides (Fig. 3.44), mirrors are used inside ducts to guide or direct light coming from the skylights to the interiors. The ducts may open at various levels. The light guides transport light using multiple specular reflection at the reflective inner wall surface. Using highly reflective silvered polyester semi-collimated mirrors, light can be transmitted over 30 m with only small losses.

Mirrors and lenses can be used to augment the availability of daylight. These follow the path of the sun by appropriate tracking mechanisms and direct the light to the desired area using sensors and control systems. Such arrangements can be used to catch the very low-angle light that the sun produces at dawn and dusk, and extend the period of useful daylight by a few hours.



Figure 3.45 shows a tracking reflector with a receiver in front for directing daylight deep into the interior in conjunction with lightwells. Additionally, there are systems that can be used to direct light to some fixed points. For example, in the Himawari system (Fig. 3.46), a honeycomb of Fresnel lenses focus the sun's light onto the ends of quartz-glass optical fibres.

The fibres are used to distribute the light deep within the interiors. A six-fibre cable of length of approximately 40 m can provide light which is comparable to the output of a 75-watt incandescent lamp.

ALMIPL SOLAR

4th Floor 4B, Mandira Apartments,
North Boag Road, T-Nagar Chennai- 600 017
Email: Solarbazaarpl@gmail.com
Web: www.almipl.com
Mobile: 94452 30332 / 9383132332

Green Energy Promoters





Fig. 3.42 Atrium

4th Floor 4B, Mandira Apartments,
North Boag Road, T-Nagar Chennai- 600 017
Email: Solarbazaarpl@gmail.com
Web: www.almipl.com
Mobile: 94452 30332 / 9383132332

Green Energy Promoters





Fig. 3.43 Light pipe

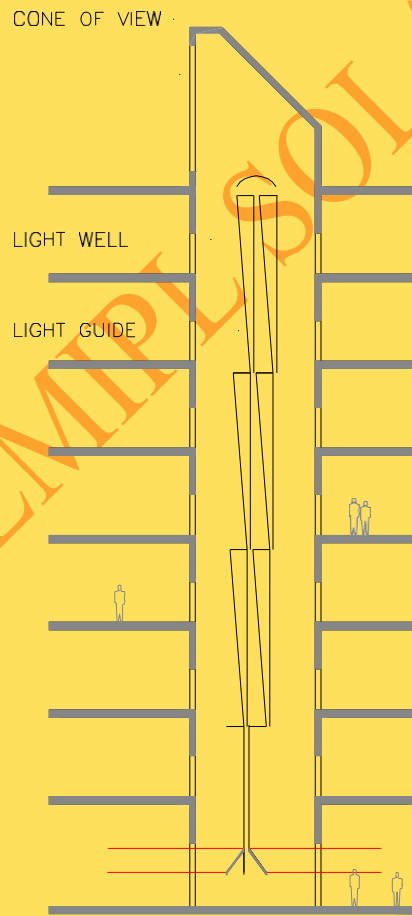

Fig. 3.44 Light well



Fig. 3.45 Sun tracking unit



Fig. 3.46 Himawari system

Laser cut light deflecting panels (LCP) can be used to deflect collimated light at low angles to penetrate the deeper zones. Light deflection results from the inner surfaces within the dielectric material, angled incident light upwards into the interiors due to total internal reflection. LCPs are formed by making laser cuts of about 2mm through a clear acrylic sheet.



Each laser cut becomes a narrow mirror internal to the sheet which reflects light incident on the sheet from directions other than normal. The angle of the laser cuts or panels can be varied for different uses:

- It can be used to direct light to the ceiling for deeper penetration. This improves daylighting and reduces glare on working planes.
- When used in skylights, (e.g. pyramidal skylights), or angle selective glazings, the noon time radiation which is directly overhead can be reflected back to the sky so that interiors do not overheat. When the angle of the sun is low (e.g. in winters, mornings and evenings), the light is directed inside.
- They can be used as louvers, which when opened, deflect the direct light back to the sky. This prevents glare and allows breeze to penetrate the building for summer cooling. When closed, they reflect light to the ceiling for deeper penetration of light in winter. Figure 3.47 shows a sketch of the working principles of LCP louvers.



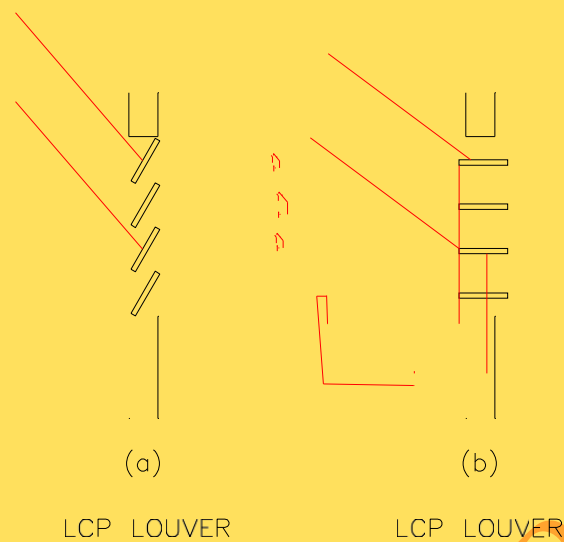

Fig. 3.47 LCP louvers
(a) tilted, (b) open

Refractive devices are devices that can be mounted on a window to redirect sunlight towards the ceiling of a room over a wide range of sun elevations. The basic component of such a device is a single solid section of dielectric with a sloping curved base and a v-shaped trough as the top surface. These are stacked together to form a module. An enclosed air gap is created between two sections. This module can be permanently mounted in a window to redirect sunlight towards the ceiling by total internal reflection. The device is generally placed in the upper parts of windows (i.e. above head height) to reduce possibility of glare and distortion of view. Figure 3.48 shows a sketch of a refracting daylighting device.



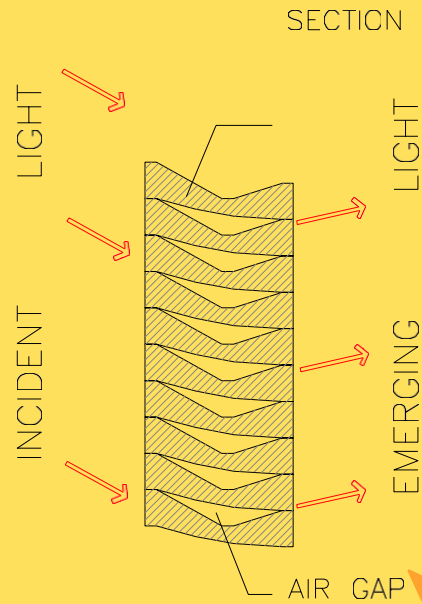

Fig. 3.48 Schematic sketch of a refractive daylighting device

3.5 BUILDING MATERIALS

There are many techniques for improving energy efficiency in buildings, and it is the responsibility of the occupants to operate it in an energy-conserving way. But occupants can operate it only within the range provided by the building's designers. It is ultimately up to the designers to provide the most energy efficient building to owners and occupants. Not only is this a service from an economic standpoint, but it will also prevent the building from becoming impracticable due to high energy costs.

Building materials play a significant role in energy conscious architecture.



The rate of heat flow through various components of a building, its time lag and amplitude decrement, as well as the energy storage capability of the building are all governed by the materials used. The choice of materials is therefore crucial from the perspective of the thermal performance of the building. Besides, the materials provide the required structural strength for the building. While the conventional building materials are well known to architects, building scientists and users (Refer to Appendix IV.1), it is desirable to focus on alternative materials to reduce costs and energy consumption. It may be noted that a certain amount of energy is consumed for the very production of the building materials from their basic raw ingredients. This is known as the *embodied energy* of the materials. This aspect has a bearing on the choice of building materials.

3.1.1 Embodied Energy of Building Materials

Energy used in the construction process and particularly in the building materials used should be minimised as a whole. Energy consumed in the procurement, manufacture, processing and recycling of building materials affects the cost of construction. The process of energy analysis consists of three steps: (i) the energy used in the production of raw materials (ii) the energy used in the making of the finished materials, and (iii). the energy used for the machinery and equipment required in the manufacturing process [31]. Sum total of these three is known as energy intensity.



Building materials have been categorized into three types based on their energy intensities. High energy materials are those with energy intensities greater than about 5GJ per ton of manufactured materials and include items like aluminum, steel, plastics, glass and cement. Medium energy group materials comprise those requiring energy inputs between 0.5 to 5 GJ per ton of material and include concrete, lime plaster and most types of blocks based on cement, lime, fly ash and fireclay bricks and tiles. Low energy group materials include fine and coarse aggregates for construction, pozzolana types of soil and stabilized soil. It is essential to promote low cost, low energy and medium energy materials for energy efficiency in building construction. However, these materials should also be durable, require less maintenance and should be recyclable. It may be noted that materials such as aluminum and steel although being highly energy intensive, can be recycled very cheaply in terms of energy.

A detailed study of the embodied energy of various building materials has been carried out by Development Alternatives, New Delhi [32]. The document provides information for different building materials and components at various levels, namely, manufacturing, processing and fabrication. A designer can obtain information on material description, technology and resources, environmental implications, production statistics, and world status on energy data. The report also presents data on energy that is consumed at the quarrying, production and transportation of raw materials, intermediate materials and finished goods.



The embodied energy of various materials is provided in Table 3.13. In addition to conventional materials, the table also includes a few alternative building materials. The primary energy required by weight, volume and/or surface area of the product is listed in the table.

Table 3.13 Energy requirements of different building materials [32]

Material	Density (kg/m ³)	Primary Energy M J thermal		
		Per tonne	Per m ³	Per m ²
Primary Materials				
Coarse Aggregate (25-40mm)	2240	240	538	-
Lime (quick)	640	6220	3968	-
Cement (OPC 33 grade)	1440	6700	9648	-
Steel (semis)	7800	-	-	-
Mini (billets)	-	23000	-	-
ISP (ingots)	32000	-	-	-
PVC (billets)	1500	158000	-	-
Secondary Materials				
Bricks weight (average 2.75 kg)	1800	1286	2235	518
Solid Concrete Blocks (30 x 20x 15) cm	2000	580	1002	209
Hollow Concrete Blocks (20 x 20 x 40) cm	1300	700	910	121
FalG Block (30 x 20 x 15) cm	2000	4400	879	127
Aerated Concrete block (19 x 19 x 39) cm	1278	6400	818	138
Steel Rods (6, 8, 10mm etc.)	7800	28212	-	-
Steel RSJ (standard sizes)	7800	42840	-	-
Steel Cold Rolled Sheets	7800	51642	-	-
Steel Hot Rolled Sheets	7800	34715	-	-
CGI	-	48276	-	302
Ferrocement (1 inch thick)	1687	3669	-	186
Cement Bonded Board (40 mm)	1250	6487	8109	324
MDF (Including raw material energy)(19 mm)	770	-	-	472
MDF (excluding raw material energy)(19mm)	770	-	-	188
Plywood (6mm thick)	700	-	-	142
Plywood (19mm thick)	700	-	-	312
Flush door (35mm thick)	700	-	-	482
PVC pipe (40 cm diameter)	1500	-	-	-

4th Floor 4B, Mandira Apartments,
 North Boag Road, T-Nagar Chennai- 600 017
 Email: Solarbazaarpl@gmail.com
 Web: www.almipl.com
 Mobile: 94452 30332 / 9383132332

Green Energy Promoters



3.1.2 Alternative Building Materials

This section presents a summary of various alternative building materials and technologies that have been developed to reduce energy consumption as well as cost [31-37].

a) Autoclaved aerated concrete (AAC)

Autoclaved aerated concrete is known more by its patented or trade name such as Siporex, Trustone and Environcrete in various parts of the world. It is a factory-produced light weight precast concrete which is available in a wide variety of shapes and sizes. A typical 200 mm thick AAC wall can be about half the weight of an ordinary hollow-core concrete block. Further, AAC blocks can be bonded by a thin layer of adhesive and thus do not need mortar. AAC blocks are made from a mixture of Portland cement, lime, silica sand or fly ash, water and aluminium powder or paste. When mixed, millions of tiny hydrogen bubbles expand the mix to approximately five times its original volume. AAC can be reinforced and can be easily cut using ordinary carpentry tools. It is a stable, non-polluting, fire resisting, thermally and acoustically insulating, and durable material. However, it needs to be plastered for protection from rain.



Fly ash

Fly ash is a by-product of coal in thermal power plants. It consists of organic and inorganic matter that is not fully burnt, and can be recycled for use in a variety of building materials. The properties of fly ash make it suitable for the manufacture of bricks, hollow and solid blocks, cellular concrete, partial replacement of cement, filler material in concrete, wood substitute, and also for use in the manufacture of emulsion paints, building distempers, etc. Using fly ash in building materials can result in a number of advantages. For example, fly ash bricks can replace burnt clay bricks, which require use of fertile agricultural soil. They are dimensionally stable having a smooth finish and fine edges, and are available in a number of sizes. They also have good resistance to weathering and need not be plastered. The bricks can be made in a number of colours using pigments. This material is being tried and tested at Central Building Research Institute, Roorkee. It has been used at IIT Delhi and The Energy Resources Institute, Gwalpahari and shown to have good results [31]. Fly ash is also used to make FaL-G (hydraulic cement). The name FaL-G stands for fly ash (Fa), Lime (L) and Gypsum (G) which are its ingredients. It can be used as an alternative to ordinary Portland cement as a binder, and to burnt clay bricks as a masonry block. It can also be used for road pavements, and in plain concrete in the form of FaL-G concrete.



b)Compressed earth blocks

The manual production of earth blocks by compressing them in small moulds has been practised for centuries. The process has now been mechanised and a variety of presses are used, including manual and hydraulic. The soil for compressed earth blocks consists of a mixture of pebbles (1.5 parts), sand (5 parts), silt (1.5 parts) and clay (2 parts). About 5 % cement is used to stabilise the earth blocks. Products range from accurately shaped solid, cellular and hollow bricks, to flooring and paving elements. Compressed earth blocks are sun dried and do not need to be burnt. They are also economical, strong, energy saving and simple to manufacture. Soil stabilised hollow and interlocking blocks can provide better thermal insulation than bricks. Mud blocks stabilised with Fal-G are much stronger, absorb less water, and are cheaper than cement stabilised blocks. Development Alternatives, New Delhi [32] and Auroville, Pondicherry have carried out extensive research on this material. A number of buildings at Auroville, Pondicherry have been built using compressed earth blocks.

c)Clay red mud burnt bricks

Clay red mud burnt bricks are produced from alumina red mud or bauxite, an industrial waste of aluminium producing plants, in combination with clay. The brick possesses all the physical properties of normal clay bricks. Incidentally, they also solve the problem of waste disposal and environmental pollution. In addition, they have good architectural value as facing bricks due to their pleasing colour.



d) Lato blocks

Lato blocks are bricks made from lateritic soil and cement or lime. The blocks are moulded under pressure to produce strong and good quality blocks which consume lesser energy than conventional bricks, and hence are cheaper. They are available in various colours ranging from cream to light crimson.

E) Precast hollow concrete blocks

Precast hollow concrete blocks are manufactured using lean cement-concrete mixes and extruded through block making machines of the egg laying or static types. They need lesser cement mortar and enable speedy construction as compared to brick masonry. The cavity in the blocks provide better thermal protection. Further, the blocks may not need external or internal plastering. These can be used as walling blocks or as roofing blocks along with inverted precast tee beams.

F)Bamboo/timber mat based walls

These walls are made up of bamboo mat placed between horizontal and vertical timber/bamboo frames. The plastering is done using mud or cement mortar on either side. These are easy to construct, cost less and are popular in hilly areas as they can be self-assembled. However, these are not load bearing and need a supporting structure. This upgraded traditional technology is a relevant option for walling from the perspective of earthquakes to minimise damage in the event of a collapse

4th Floor 4B, Mandira Apartments,
North Boag Road, T-Nagar Chennai- 600 017

Email: Solarbazaarpl@gmail.com

Web: www.almipl.com

Mobile: 94452 30332 / 9383132332

Green Energy Promoters



G)Rat trap bond

The rat trap bond is an alternative brick bonding system for English and Flemish bond. It is economical, strong and aesthetically appealing. It can save about 25% of the total number of bricks and about 40% of the mortar cost for a wall. The rat trap bond is simple to build and has better insulation properties.

H)Composite ferrocement system

The system is simple to construct and is made of ferrocement (rich mortar reinforced with chicken mesh and welded wire mesh). These reduce the wall thickness and allow a larger carpet area. Precast ferrocement units in trough shape are integrated with RCC columns. Ferrocement units serve as a permanent skin unit, and as a diagonal strut between columns. Inside cladding can be done with mud blocks or any locally available material. These are ideally suited for seismic areas.

c)Coconut fibre and wooden chips roofing sheets

Coconut fibre and wooden chips or fibre are soaked in water for two hours and after which the water drained off. These are then mixed with cement, laid over a corrugated mould and kept under pressure for 8 to 10 hours. After demoulding, the sheets are cured and dried before use.

J) Cement bonded fibre roofing sheets

These are made from coir waste, coconut pith, wood wool or sisal fibre in combination with cement as binder, for production of corrugated or plain roofing sheets.



These sheets use lesser cement than AC sheets and are 50% cheaper than AC/CGI sheets. Besides, they are light weight, fire resistant, water proof and can be used for sloping roof options.

k)Micro concrete roofing tiles

Micro concrete roofing tiles are made of graded cement mortar layer and formed over sloping mould. They are used in pitched roofing systems and are less expensive than ACC/CGI sheets. These tiles are appropriate where fired clay tiles are not available, and timber supporting skeletal system is costlier. The rafter and purlin system cost less when micro concrete roofing tiles are used. Further cost reduction can be made by using ferrocement rafters and purlins.

L)Stone patti roofing:

Stone patti roofing is a flat roofing system with sand stone slabs (patties) resting over steel or slender RCC section beams. The slabs are overlaid with terracing for insulation. This type of roofing is appropriate where (sand) stone slabs are available, and is more economical than RCC slabs. In places like the states of Rajasthan, Madhya Pradesh and Andhra Pradesh where large granite stone patties are available, the beams are not needed as the pattis can rest on walls.



M)Precast brick arch panel system

In this technique, precast brick arches of size 50cm x 50cm are cast on a platform. The arches are placed side by side over the partially precast joist. The haunches between the arches are filled with cement concrete to have a level surface on the top. Such roofs/floors are 30 percent more economical when compared with conventional RCC.

N) Filler slabs

Filler slabs are normal RCC slabs in which bottom half (tension) concrete portions are replaced by filler materials such as bricks, tiles, cellular concrete blocks, etc. Filler materials are so placed as not to compromise structural strength; they replace unwanted and non-functional tension concrete, thus resulting in economy. These are safe, sound and provide aesthetically pleasing pattern for ceilings. An additional advantage of filler slabs is that they do not need plastering.

O)Particle boards

Particle boards are made from wood waste, cotton stalk and bagasse, and bonded by resin. They can be used as inserts, and with veneering, they can be used as an alternative to timber in panelling, false ceiling flooring, partitioning and furniture.

Table 3.14 gives the possible savings that could be achieved by using alternative building materials [37].



Table 3.14 Estimated cost savings on using innovative building materials [37]

S. No.	Cost-Effective Technologies	In place of Conventional options	% of Saving
I. FOUNDATIONS			
1.	Pile foundation (under reamed)	Traditional stone/bricks	15
2.	Brick Arch foundations	Footings	25
II. WALLING (SUPER STRUCTURE)			
1.	230 mm Thick wall in lower floors	330 mm brick walls	5
2.	180 mm Thick wall in bricks	230 mm brick walls	13
3.	115 mm thick recessed walls	230 mm brick walls	20
4.	150/200 mm Stone block masonry'	Random rubble masonry	30-20
5.	Stabilised mud blocks	Burnt brick walls	20
6.	FaL-G Block masonry	Clay brick walls	20
7.	Fly ash brick walls	Gay brick walls	25
8.	Rat trap bond walls	English/Flemish bond	25
9.	Hollow blocks walls	Solid masonry	20
III ROOFING			
1.	85 mm thick sloping RCC	110 mm RCC	30
2.	Tiles over RCC rafters	Tiles over timber rafters	25
3.	Brick panel with joists	RCC	20-25
4.	Cuddapah slabs over RCC rafters	CS over timber rafters	20
5.	L-panel sloping roofing	RCC	10
6.	RCC planks over RCC joists	RCC	10
7.	Ferrocement shell roofing	RCC	40
8.	Filler slab roofing	RCC	22
9.	Waffle roofing	RCC	15
10.	RCC channel units	RCC	12
11.	Jack arch brick roofing	RCC	15
12.	Funicular shell roofing	RCC	18
13.	Brick funicular shell roofing	RCC	30
14.	Precast blocks over inverted T-beams	RCC	25
15.	Micro-concrete roofing tiles	Clay tile roofing AC sheet roofing	20-15
IV. MISCELLANEOUS ITEMS			
1.	RCC door frames	Timber Frames	30
2.	Frameless doors (only inserts)	Frames and shutters	50
3.	Ferrocement door shutters	Timber shutters (second class timber)	30
4.	RCC window frames	Timber frames	30
5.	RCC jellies	Timber windows/ventilators	50
6.	Precast thin lintels	RCC lintels	25
7.	Precast sunshades	Cast sunshades	30
8.	Ferrocement sun shades-cum-lintel	RCC lintel-cum-sunshades	50
9.	Brick on edge lintels	RCC lintels	50
10.	Corbelling for lintels	RCC lintels	40
11.	Brick arch-for lintels	RCC lintels	30
12.	Precast RCC shelves units	Timber/concrete	20-35
13.	Precast Ferrocement shelves	Timber/concrete	35-45
14.	Ferrocement manhole covers	Casion/concret e	50-40
15.	Ferrocement water tank	Rigid PVC	60

References

1. Nayak J.K., Hazra R. and Prajapati J., *Manual on solar passive architecture*, Solar Energy Centre, MNES, Govt. of India, New Delhi, 1999
2. Bureau of Indian Standards, *National building code of India 1983 - incorporating amendments No.1 and 2*, Bureau of Indian Standards, New Delhi, 1990
3. Nayak J.K. and R. Hazra, *Development of design guidelines on solar passive architecture and recommendations for modifications of building bye-laws*, Final Report, R & D Project no. 10/86/95-ST, 1999.
4. *IS:3792-1978, Guide for heat insulation of non-industrial buildings - First Revision*, Bureau of Indian Standards, New Delhi, 1979
5. *SP: 41 (S&T) -1987 - Handbook on functional requirements of buildings*, Bureau of Indian Standards, New Delhi, 1987.
6. Vaughn Bradshaw, P.E., *Building control systems*, John Wiley and Sons, New York, 1985
7. *Advanced glazing materials - part A*, Solar Energy, Volume 62, No. 3, 1998
8. *Advanced glazing materials - part B*, Solar Energy, Volume 63, No. 4, 1998.
9. Bandyopadhyay B., *The energy-efficient glazings*, Chapter in "Energy Efficient Buildings of India" (ed. M. Majumdar), Tata Energy Research Institute, New Delhi, 2001.
10. Mazria E., *The passive solar energy book*, Rodale Press, Pennsylvania, 1979.
11. Bansal N.K., Hauser G. and Minke G., *Passive building design*, Elsevier Science, New York, 1994.

4th Floor 4B, Mandira Apartments,
North Boag Road, T-Nagar Chennai- 600 017

Email: Solarbazaarpl@gmail.com

Web: www.almipl.com

Mobile: 94452 30332 / 9383132332

Green Energy Promoters



12. Levy M.E., Evans D. and Gardstein C., *The passive solar construction handbook*, Rodale Press, Pennsylvania, 1983.
13. Majumdar M., *Energy efficient buildings of India*, Tata Energy Research Institute, New Delhi, 2001
14. Givoni B., *Passive and Low energy cooling of buildings*, Van Nostrand Reinhold, New York, 1994
15. Bahadori M.N., *Passive cooling systems in Iranian architecture*, Science American, Volume 238, issue no.2, 144, 1978.
16. Bahadori M.N., *Natural cooling in hot arid regions*, in Solar Energy Application in Buildings, pp. 195 – 225 (edited by A.A.M. Sayigh), Academic Press, New York, 1979.
17. Sodha M. S., Bansal N.K., Bansal P. K., Kumar A. and Malik M. A. S., *Solar passive building: science and design*, Pergamon Press, Oxford, New York, 1986
18. Watt J. R., *Evaporative air conditioning*, The Industrial Press, New York, 1963
19. Goulding J.R., Lewis J. O. and Steemers T.C. (Ed.), *Energy in architecture – the European passive solar handbook*, B.T. Batsford Ltd., London, 1992
20. Thompson T.L., Chalfoun N.V. and Yoklic M.R., *Estimating the performance of natural draft evaporative coolers*, Energy Conversion and Management, 35, 909, 1994.
21. Givoni B., *Semiperical model for a building with a passive evaporative cool tower*, Solar Energy, 50, 425, 1993.

4th Floor 4B, Mandira Apartments,
North Boag Road, T-Nagar Chennai- 600 017

Email: Solarbazaarpl@gmail.com

Web: www.almipl.com

Mobile: 94452 30332 / 9383132332

Green Energy Promoters



22. Givoni B., *Performance of the “shower” cooling tower in different climates*, Renewable Energy 10, 173, 1997.
23. Kumar A. and Purohit I., *Thermal performance evaluation of roof surface evaporative cooling system for Indian locations*, Proc. ICORE 2005, Pune, pp. 179 - 186, 2005.
24. Sawhney R.L. and Mahajan U., *Heating and cooling potential of an underground air-pipe system*, Int. J. Energy research, 18, pp. 509 - 524, 1994.
25. Sodha M.S., Mahajan U. and Sawhney R.L., *Thermal performance of parallel earth air-pipe system*, Int. J. Energy research, 18, pp. 437 - 447, 1994.
26. Thanu N.M., Sawhney R.L., Khare R.N. and Budhi D., *An experimental study of thermal performance of an earth air-pipe system in single pass mode*, Solar Energy, 71, pp. 353 - 364, 2001.
27. Fontoynt M. (Ed.), *Daylight performance of buildings*, James & James (Science Publishers) Ltd., London, 1999.
28. Baker N. and Steemers K., *Daylight design of buildings*, James & James (Science Publishers) Ltd., London, 2002.
29. Misra A. and Kumar P., *Energy efficient lighting and daylighting in buildings-a primer*, Tata Energy Research Institute Report, 1995.



30. Baker N. and Steemers K., *Daylight design of buildings*, James & James (Science Publishers) Ltd., London, 2002.
31. Misra A. and Kumar P., *Energy efficient lighting and daylighting in buildings-a primer*, Tata Energy Research Institute Report, 1995.
32. Koenigsberger O.H., Ingersoll T.G., Mayhew A. and Szokolay S.V., *Manual of tropical housing and building, part 1 - climatic design*, Orient Longman, Madras, 1975.
33. Bansal N. K. and Cook J. (Ed), *Sustainability through building*, Omega Scientific, New Delhi, 2001
34. Development Alternatives, *Energy directory of building materials*, Project Sponsored by Building Materials and Technology Promotion Council, BMTPC, 1995
35. HUDCO Build-Tech, *Brochure of housing and urban development corporation Ltd.*, New Delhi, November, 1999.
36. Bhanumathidas N. and Kalidas N., *FaL-G: the hydraulic cement*, Proc. National workshop on alternative building methods (Ed. K.S. Jagadish and K.S. Nanjunda Rao), January 16 - 18, IISc., Bangalore, 2002, pp.17 - 23.
37. Jagadish K.S. and Rao K.S.N., *Ferrocement: materials and applications*, Proc. National workshop on alternative building methods (Ed. K.S. Jagadish and K.S. Nanjunda Rao), January 16 - 18, IISc., Bangalore, 2002, pp.24 - 32.



38. Ganesh K.R. and Reddy B.V.V., *Appropriate roofing alternatives and their relevance*, Proc. National workshop on alternative building methods (Ed. K.S. Jagadish and K.S. Nanjunda Rao), January 16 - 18, IISc., Bangalore, 2002, pp.66 - 69.
39. Suresh V., *Alternative building materials and technology dissemination*, Proc. National workshop on alternative building methods (Ed. K.S. Jagadish and K.S. Nanjunda Rao), January 16 - 18, IISc., Bangalore, 2002, pp.163 - 170.

ALMIPL SOLAR

4th Floor 4B, Mandira Apartments,
North Boag Road, T-Nagar Chennai- 600 017
Email: Solarbazaarpl@gmail.com
Web: www.almipl.com
Mobile: 94452 30332 / 9383132332

Green Energy Promoters



APPENDIX III.1

EFFECT OF SHADING DEVICES

The heat gain through windows has a major role in controlling the indoor temperatures in case of non-conditioned buildings and heating and cooling load in case of conditioned buildings. It is therefore necessary to examine the effect of various chajja-fin combinations to reduce the heat gain. For this purpose the amount of direct solar radiation incident on windows has been considered as the basis. The effect of size of chajja, fin, gap, extension and windows in the four cardinal directions (i.e. north, east, south and west) has been studied. These terms are defined as follows:

Fin/Chajja depth: Projection outward from the wall,. (When a chajja is assumed to have a depth of say X meters, all the fins are also assumed to have a depth of X meters. The chajja and fin meet at an edge at top)

Fin length :Length measured from the top edge of the window to the bottom of the fin. (Four cases considered are: no fin, fin upto one third of window height measured downwards from top edge of window, fin upto two third of window height measured downwards from top edge of window and fin upto window height measured downwards from top edge of window).



Gap : The distance between the top edge of window and the chajja Extension :The distance between the left or right fin to the nearest vertical edge of window. In case there is no fin, it is the length by which the chajja extends beyond the width of the window.(Extension is assumed equal on both sides of the window)

Figure III.1 illustrates these terms graphically.

The various cases considered are:

Window size : 0.6 x 1.2 , 0.6 x 1.8, 1.2 x 1.2, 1.2 x 1.8, 1.8 x 1.2, 1.8 x 1.8 (m²)

Fin/Chajja depth: 0.0, 0.3, 0.6, 1.0 (m)

Fin length : No fin,
: Upto 1/3 of window height measured from top.
: Upto 2/3 of window height measured from top.
: Equal to the window height.

Gap : 0.0, 0.15(m)

Extension : 0.0, 0.15(m)

Windows are given a set back of 0.1 m from the exterior surface of the wall.



Beam radiation incident on the window per unit area (i.e., Beam radiation on window X (Window area - Shaded area) / Window area) is found out for the hours between 9 a.m. to 4 p.m. (IST) for all days of the year. This particular time span has been chosen to avoid the absurd values, which may crop in due to the low magnitudes of the trigonometric functions for hours before 9 a.m. and after 4 p.m. It may be mentioned that the intensities of solar radiation before 9 am and after 4p.m. are generally small. So the assumption does not lead to significant error. Further, this calculation has been used for relative comparisons. These hourly values are summed up over the year to yield yearly total radiation incident on window.

Yearly beam solar radiation incident on windows for various chajja-fin combinations have been estimated for Mumbai, Pune, Ahmedabad and Nagpur. Table III.1 presents results of such calculations for a window of size 1.2m X 1.2m. Tables show the percentage radiation incident for various chajja-fin combinations as compared to an unshaded window (with no chajja or fin). The radiation falling on an unshaded window (over the year) in each of the directions corresponding to different climates is given at the end of the table. To find out the actual radiation per unit area of window with shading device/s, multiply the radiation on unshaded window with the corresponding number from the table and divide by 100.



Radiation
falling on
window \square

$$\frac{P \times Q}{100} \quad \text{Wh/m}^2 \text{ - year} \quad \dots(\text{III.1})$$
$$= \frac{P \times Q \times R}{100} \quad \text{Wh/year} \quad \dots\dots\dots(\text{III.2})$$

Total radiation on the
window

ALMIPL SOLAR

Where : P = Percentage of radiation falling on shaded window.
Q = Radiation on
unshaded window R =
Window area (m^2)

The radiation blocked by the shading device is the difference of the radiation on the unshaded window and that on the shaded window. The smaller is the value of P, the better is the performance of window shading device combination. By keeping this fact in mind, one can find out the best window shading device combination for any of the four cities and in any of the four directions.

It is seen that providing a chajja in general reduces the radiation incident on windows. This is as expected. If, however, a gap between the top of the window and chajja is provided, the shading decreases and the percentage of radiation increases. In addition, if fins are provided, the percentage further reduces in general. However, providing an extension leads to a decrease in shading since the fins are moved apart. This leads to an increase in the percentage of radiation incident. But the reverse is the case if a window does not have fins.



From these results the relative performance of the shading combinations can be found out. For an example, consider a window with 0.6m chajja, 0.15m extension, zero gap and no fin, the percentage of radiation incident on south window is 72.3% compared to an unshaded window for Ahmedabad climate. But for a window with 1.0m chajja, zero extension, zero gap and full fins, the corresponding number is 14.8%. A graphical representation of such behaviour for all cities corresponding to a few cases has been shown in Fig. III.2. The results for other window sizes are reported in Table III.2.

From Tables III.1 and III.2, the best combination of shading devices can be identified. For an example, for north facing window in Ahmadabad, the percentage of radiation incident is the least (57%) for a chajja depth of 0.3m, full fin length, zero extension and zero gap. Such combinations have been identified for all window sizes corresponding to four cities and are listed in Table III.3. The magnitudes of the radiation incident on such windows are also listed in the table. The numbers in parentheses give the corresponding radiation value for unshaded window. These provide ready reference for comparison of different cases.



Appropriate window sizing and shading combinations in different orientations can be found from the table. For example, it is found that in Ahmadabad, a large window of 1.8 m x 1.8 m in the north shaded by a chajja of depth 0.6m and full fins performs better than a well-shaded smaller window of 0.6 m x 1.2 m (protected by 1.0m chajja and full fins) in the east, west and south. The magnitude of radiation incident on window reduces by more than 3 times. Thus, it may be inferred that larger windows should preferably be located in the north. Conversely, smaller windows should be provided in the other directions and they should be well shaded. It is also seen that out of two windows (width 1.2m, height 1.8m and width 1.8m, height 1.2m), the one with higher height is better since the percentage of radiation incident is lower.

This is because of the fact that the shading increases for a window of higher height compared to a wider one, when fins are also provided. A combination of deep chajjas and full-fins of 1.0m depth can significantly reduce the radiation falling on a large window (1.8m X 1.8m); the values are ranging from about 3.5 times in the east to 4.9 times in the south. Hence, chajja and full-fin combinations are very effective in reducing the heat gain through windows.



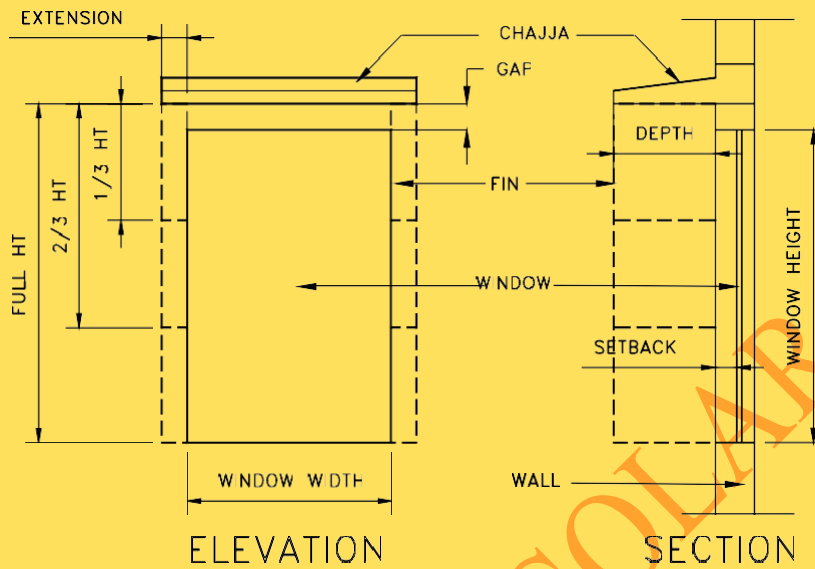

Fig. III.1 Illustrations of chajja depth, fin length, gap and extension

ALMIPL SOLAR

4th Floor 4B, Mandira Apartments,
 North Boag Road, T-Nagar Chennai- 600 017
 Email: Solarbazaarpl@gmail.com
 Web: www.almipl.com
 Mobile: 94452 30332 / 9383132332

Green Energy Promoters



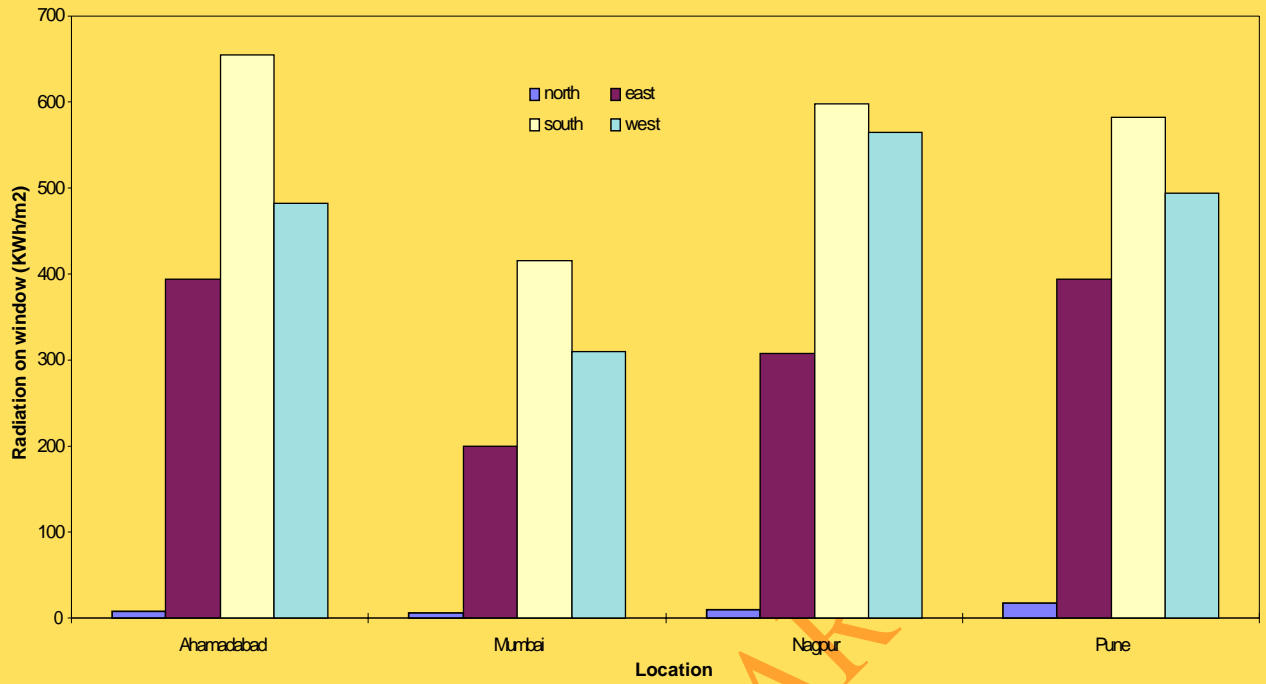

Fig. III.2 (Case 1) Radiation on unshaded 1.2m x 1.2 m window

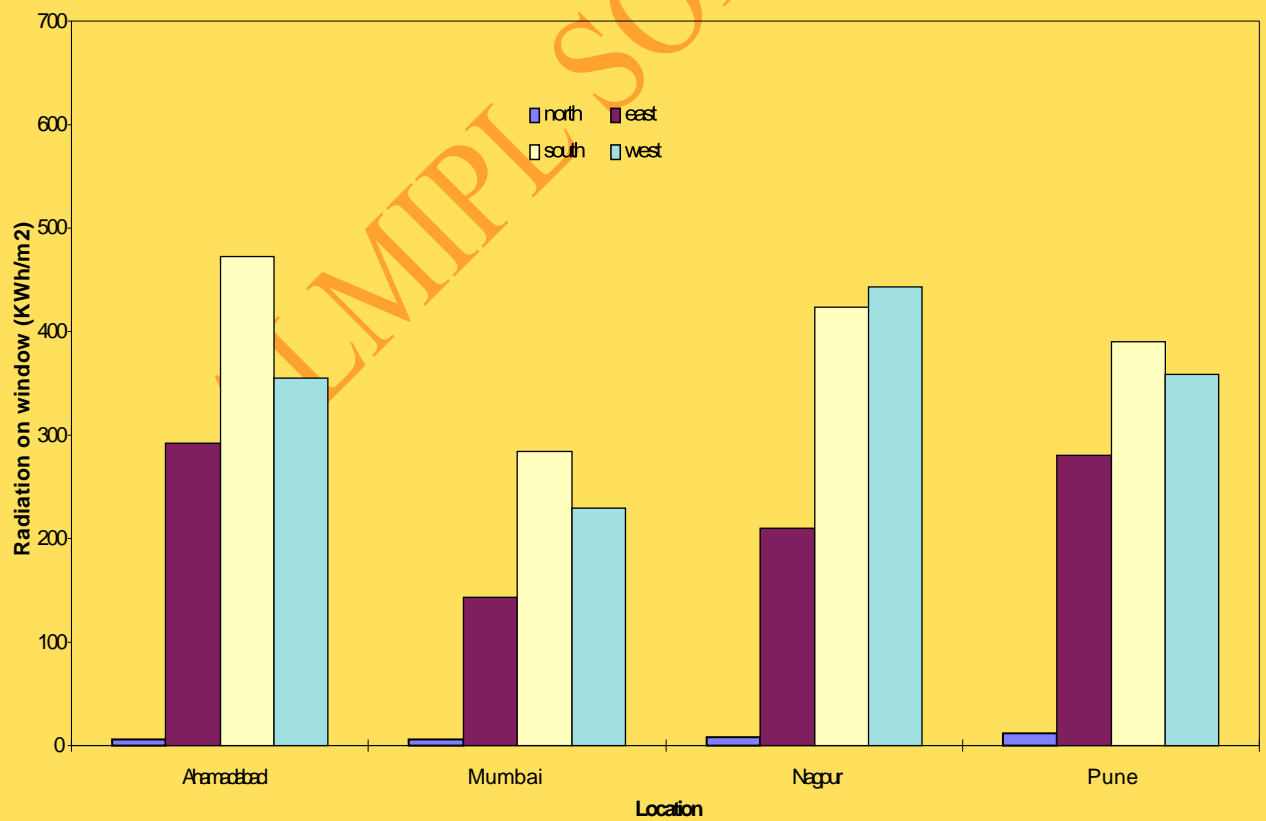

Fig. III.2 (Case 2) Radiation on 1.2m x 1.2 m window shaded by 0.6 m chhajja with 0.15 m extension

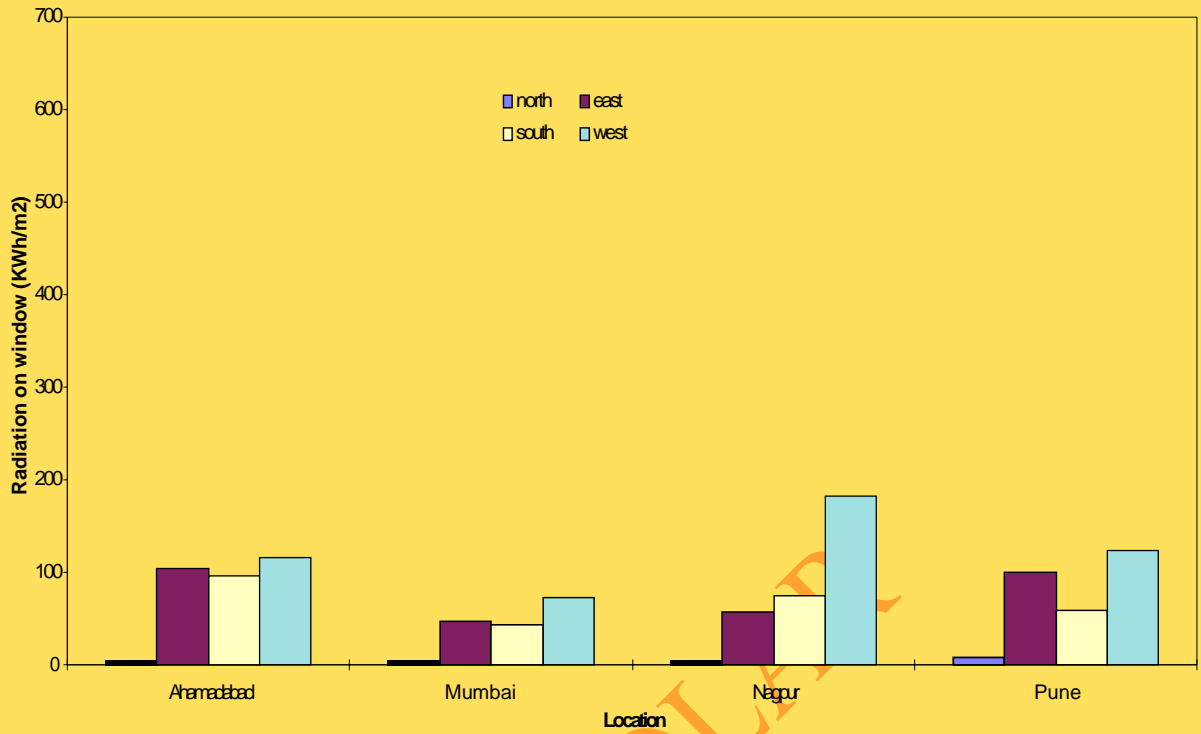

Fig. III.2 (Case 3) Radiation on 1.2m x 1.2 m window shaded by 0.6 m chhajja and full fins

ALMIPL SOLAR

4th Floor 4B, Mandira Apartments,
 North Boag Road, T-Nagar Chennai- 600 017
 Email: Solarbazaarpl@gmail.com
 Web: www.almipl.com
 Mobile: 94452 30332 / 9383132332

Green Energy Promoters



Table III.1 Percentage of beam radiation incident on window (1.2m wide by 1.2m height)

Parameters				Percentage radiation incident (%)															
				Ahmadabad				Mumbai				Nagpur				Pune			
ext	fin	gap	CL	North	East	South	West	North	East	South	West	North	East	South	West	North	East	South	West
0	0	0	0.3	95.30	94.74	95.84	96.35	89.86	94.22	95.88	96.37	91.12	94.81	95.43	95.59	83.18	94.48	94.86	95.92
0	0	0	0.6	95.30	76.97	75.98	76.59	89.86	75.94	72.83	77.54	91.12	71.69	74.62	80.84	83.11	74.04	71.65	75.78
0	0	0	1	95.30	58.64	57.21	55.74	89.86	58.94	52.62	57.73	91.12	50.25	55.81	62.77	83.11	54.15	52.75	54.97
0	0	0.15	0.3	98.79	97.10	98.06	98.47	93.79	96.95	98.20	98.49	96.25	97.72	97.96	97.58	88.90	97.09	97.36	98.13
0	0	0.15	0.6	98.79	85.13	85.43	84.96	93.77	84.27	83.16	85.63	96.25	80.91	84.24	87.80	88.82	82.99	81.80	84.24
0	0	0.15	1	98.79	67.85	65.81	65.30	93.77	68.19	61.90	67.65	96.25	59.19	64.40	71.68	88.82	63.87	61.64	64.89
0	1/3	0	0.3	75.10	91.75	92.01	93.70	75.01	90.59	91.98	93.55	67.34	91.85	91.42	93.19	61.95	91.71	90.73	93.47
0	1/3	0	0.6	75.10	68.93	65.17	68.93	74.82	66.54	61.51	69.20	67.34	63.24	63.35	74.11	61.17	66.66	59.80	68.50
0	1/3	0	1	75.10	45.81	40.46	43.14	74.82	44.32	35.24	43.96	67.34	37.09	38.73	51.27	61.17	42.35	35.20	42.94
0	1/3	0.15	0.3	70.59	92.40	91.93	94.24	73.75	91.35	91.99	94.00	63.42	93.01	91.54	93.72	59.93	92.80	90.83	94.21
0	1/3	0.15	0.6	70.59	73.53	69.75	73.90	73.52	70.84	66.85	73.64	63.42	68.85	67.89	77.92	59.00	72.42	64.78	73.74
0	1/3	0.15	1	70.59	49.93	42.32	47.72	73.52	47.96	37.74	48.54	63.42	41.04	40.43	55.47	59.00	47.54	37.27	48.17
0	2/3	0	0.3	59.20	87.52	86.22	89.65	64.55	85.73	86.09	89.30	48.19	87.44	85.33	89.52	45.92	87.89	84.62	89.73
0	2/3	0	0.6	59.20	60.26	53.05	60.55	64.31	56.81	49.09	60.21	48.19	54.43	50.70	66.30	44.98	58.92	46.94	60.58
0	2/3	0	1	59.20	33.70	24.29	31.24	64.31	31.14	19.21	31.25	48.19	25.39	22.28	39.88	44.98	31.65	19.06	31.77
0	2/3	0.15	0.3	60.83	88.44	86.40	90.34	66.82	86.81	86.28	89.93	50.19	88.84	85.69	90.23	49.01	89.17	84.95	90.61
0	2/3	0.15	0.6	60.83	65.69	58.55	66.23	66.58	62.13	55.41	65.42	50.19	60.93	56.17	70.72	48.07	65.44	53.01	66.49
0	2/3	0.15	1	60.83	39.43	28.26	37.34	66.58	36.68	24.06	37.51	50.19	31.09	26.19	45.35	48.07	38.33	23.50	38.45
0	full	0	0.3	56.99	84.03	81.25	86.15	62.24	81.79	80.89	85.66	43.56	83.86	80.01	86.35	42.09	84.71	79.34	86.47
0	full	0	0.6	56.99	54.11	44.39	54.47	62.01	50.16	40.55	53.75	43.56	48.52	41.59	60.38	41.16	53.54	38.29	54.82

Continued

Table III.1 Percentage of beam radiation incident on window (1.2m wide by 1.2m height) Continued from previous page

Parameters				Percentage radiation incident (%)															
				Ahmadabad				Mumbai				Nagpur				Pune			
ext	fin	gap	CL	North	East	South	West	North	East	South	West	North	East	South	West	North	East	South	West
0	full	0	1	56.99	26.28	14.76	23.94	62.01	23.36	10.18	23.62	43.56	18.77	12.45	32.33	41.16	25.31	9.98	24.95
0	full	0.15	0.3	60.48	85.70	82.54	87.60	66.16	83.81	82.36	87.09	48.68	86.14	81.54	87.64	47.81	86.74	80.98	88.03
0	full	0.15	0.6	60.48	61.39	52.83	62.03	65.93	57.62	49.99	61.00	48.68	57.04	50.13	66.36	46.88	61.77	47.54	62.50
0	full	0.15	1	60.48	34.61	22.34	32.68	65.93	31.72	18.57	32.70	48.68	27.01	19.97	40.23	46.88	34.31	17.98	34.10
0.15	0	0	0.3	89.89	94.06	95.22	95.89	84.52	93.35	95.28	95.85	83.96	94.20	94.76	95.07	75.66	93.82	94.09	95.42
0.15	0	0	0.6	89.89	74.01	72.28	73.69	84.32	72.27	68.65	74.39	83.86	68.10	70.81	78.49	75.01	70.84	67.14	72.78
0.15	0	0	1	89.89	52.70	49.76	49.69	84.32	52.02	44.33	51.10	83.86	43.20	48.38	57.58	75.01	47.79	44.28	48.66
0.15	0	0.15	0.3	95.55	96.66	97.73	98.25	89.36	96.41	97.89	98.22	91.13	97.42	97.61	97.24	82.69	96.69	96.89	97.87
0.15	0	0.15	0.6	95.55	83.03	82.97	82.86	89.15	81.61	80.37	83.32	91.04	78.20	81.72	86.14	81.98	80.67	78.69	82.06
0.15	0	0.15	1	95.55	62.90	59.49	60.30	89.15	62.34	54.81	62.18	91.04	53.06	58.13	67.43	81.98	58.44	54.32	59.61
0.15	1/3	0	0.3	67.77	92.61	93.23	94.78	70.69	91.53	93.40	94.76	60.32	92.87	92.64	94.10	56.76	92.60	91.93	94.52
0.15	1/3	0	0.6	67.77	68.21	63.84	68.25	69.65	65.35	59.86	68.50	59.27	61.88	61.73	73.92	53.38	65.85	57.85	67.89
0.15	1/3	0	1	67.77	42.29	35.06	39.48	69.65	39.99	29.03	40.02	59.27	32.46	32.98	48.50	53.38	38.70	28.66	39.37
0.15	1/3	0.15	0.3	67.55	94.71	94.86	96.70	71.96	93.99	95.18	96.73	60.41	95.57	94.56	95.92	58.29	95.07	93.80	96.65
0.15	1/3	0.15	0.6	67.55	75.17	71.28	75.46	70.85	72.30	68.26	75.37	59.23	69.87	69.18	79.86	54.68	73.97	65.92	75.45
0.15	1/3	0.15	1	67.55	49.04	39.58	46.66	70.85	46.42	34.26	47.44	59.23	38.92	37.31	55.23	54.68	46.43	33.37	47.26
0.15	2/3	0	0.3	57.47	91.46	91.13	93.72	63.89	90.15	91.33	93.79	46.72	91.60	90.36	93.29	46.13	91.67	89.60	93.76
0.15	2/3	0	0.6	57.47	63.36	55.96	63.61	62.79	59.81	51.76	63.57	45.54	56.89	53.29	69.85	42.57	61.86	49.41	63.81
0.15	2/3	0	1	57.47	34.31	22.87	31.53	62.79	31.17	16.98	31.59	45.54	24.80	20.36	41.14	42.57	32.04	16.46	32.31
0.15	2/3	0.15	0.3	62.65	93.75	92.98	95.75	68.03	92.84	93.23	95.88	52.21	94.47	92.45	95.25	51.89	94.28	91.62	95.98
0.15	2/3	0.15	0.6	62.65	71.05	64.29	71.44	66.92	67.65	61.06	71.11	51.04	65.64	61.61	76.31	48.28	70.61	58.46	71.91

Continued

Table III.1 Percentage of beam radiation incident on window (1.2m wide by 1.2m height) Continued from previous page

Parameters				Percentage radiation incident (%)															
				Ahmadabad				Mumbai				Nagpur				Pune			
ext	fin	gap	CL	North	East	South	West	North	East	South	West	North	East	South	West	North	East	South	West
0.15	2/3	0.15	1	62.65	42.48	29.51	40.08	66.92	39.34	24.60	40.51	51.04	32.81	26.89	48.99	48.28	41.06	23.60	41.45
0.15	full	0	0.3	56.99	90.86	89.66	93.09	63.11	89.46	89.77	93.28	44.74	90.96	88.63	92.86	44.72	91.21	87.88	93.35
0.15	full	0	0.6	56.99	60.67	51.23	60.91	62.01	56.94	47.15	60.81	43.56	54.34	48.06	67.36	41.16	59.78	44.67	61.47
0.15	full	0	1	56.99	30.43	17.21	27.64	62.01	27.22	11.85	27.68	43.56	21.58	14.27	37.12	41.16	29.08	11.26	28.97
0.15	full	0.15	0.3	62.63	93.44	92.00	95.41	67.95	92.50	92.23	95.64	51.91	94.16	91.27	95.01	51.75	94.07	90.54	95.78
0.15	full	0.15	0.6	62.63	69.54	61.68	69.94	66.85	66.14	58.69	69.63	50.73	64.36	58.67	74.80	48.13	69.52	56.03	70.64
0.15	full	0.15	1	62.63	40.47	26.70	38.12	66.85	37.40	22.16	38.65	50.73	31.35	23.73	46.74	48.13	39.64	21.12	39.83

Radiation on unshaded window (1.2m wide by 1.2m height)

	<u>North (Wh/m²-year)</u>	<u>East (Wh/m²-year)</u>	<u>South (Wh/m²-year)</u>	<u>West (Wh/m²-year)</u>
Ahmadabad	7219	394074	654682	482717
Mumbai	5865	199200	414788	308871
Nagpur	9537	307567	598595	564900
Pune	16700	394949	581880	494051

Table III.2(A) Percentage of beam radiation incident on window (0.6m wide by 1.2m height)

Parameters				Percentage radiation incident (%)															
				Ahmadabad				Mumbai				Nagpur				Pune			
ext	fin	gap	CL	North	East	South	West	North	East	South	West	North	East	South	West	North	East	South	West
0	0	0	0.3	100.00	96.07	97.04	97.32	99.78	96.05	97.08	97.55	100.00	96.07	96.75	96.68	98.64	95.82	96.36	96.98
0	0	0	0.6	100.00	82.67	82.89	82.16	99.78	83.63	80.76	84.18	100.00	78.45	81.73	85.55	98.64	80.17	80.00	81.55
0	0	0	1	100.00	69.87	71.36	67.32	99.78	73.35	68.57	71.65	100.00	63.38	70.07	72.91	98.64	66.20	68.63	67.26
0	0	0.15	0.3	100.00	97.91	98.72	98.93	99.90	98.03	98.82	99.08	100.00	98.25	98.66	98.27	99.23	97.89	98.27	98.74
0	0	0.15	0.6	100.00	89.07	90.10	89.00	99.90	89.81	88.42	90.55	100.00	85.97	89.02	91.15	99.23	87.46	87.53	88.56
0	0	0.15	1	100.00	76.87	77.87	74.44	99.90	80.08	75.52	78.94	100.00	70.18	76.59	79.81	99.23	73.95	75.31	75.01
0	1/3	0	0.3	98.15	90.87	90.10	92.41	94.10	89.76	89.81	92.05	93.98	90.44	89.54	92.27	86.59	90.91	88.59	92.15
0	1/3	0	0.6	98.15	69.75	66.39	69.42	94.10	68.20	63.34	69.80	93.98	64.77	65.02	73.81	86.59	67.49	62.36	68.79
0	1/3	0	1	98.15	51.86	50.28	49.40	94.10	52.57	46.75	51.46	93.98	45.10	49.15	55.63	86.59	48.55	46.87	48.96
0	1/3	0.15	0.3	96.14	89.42	87.30	90.83	90.01	87.91	86.91	90.06	88.44	89.16	86.75	90.96	79.43	89.98	85.66	90.87
0	1/3	0.15	0.6	96.14	69.75	65.45	69.95	90.01	66.94	62.55	69.20	88.44	65.80	63.94	73.41	79.43	68.77	61.41	69.68
0	1/3	0.15	1	96.14	50.71	47.22	48.49	90.01	50.03	44.04	49.82	88.44	43.93	46.08	54.57	79.43	48.63	43.94	48.73
0	2/3	0	0.3	92.89	82.46	78.60	84.19	84.19	79.97	77.85	83.02	79.99	81.59	77.47	84.85	67.90	83.23	76.16	84.33
0	2/3	0	0.6	92.89	53.58	45.74	53.40	84.19	49.42	41.92	52.08	79.99	48.34	43.85	58.62	67.90	52.33	40.91	53.23
0	2/3	0	1	92.89	31.56	26.75	29.37	84.19	29.45	23.21	29.15	79.99	25.41	25.59	35.68	67.90	29.53	23.50	29.06
0	2/3	0.15	0.3	90.93	81.24	76.08	82.82	81.61	78.43	75.20	81.30	75.33	80.62	74.96	83.76	63.51	82.55	73.56	83.30
0	2/3	0.15	0.6	90.93	54.37	45.79	54.68	81.61	49.23	42.27	52.38	75.33	50.31	43.86	58.90	63.51	54.50	41.21	54.94
0	2/3	0.15	1	90.93	31.85	25.78	29.91	81.61	28.65	22.77	29.17	75.33	25.95	24.68	35.87	63.51	31.20	22.86	30.38
0	full	0	0.3	89.94	75.03	68.07	76.86	79.95	71.58	66.83	75.10	71.54	74.08	66.35	78.19	59.45	76.63	64.91	77.51
0	full	0	0.6	89.94	40.69	29.38	40.51	79.95	35.25	25.62	38.27	71.54	36.10	27.29	46.16	59.45	40.92	24.78	41.18

Continued

Table III.2(A) Percentage of beam radiation incident on window (0.6m wide by 1.2m height) Continued from previous page

Parameters				Percentage radiation incident (%)															
				Ahmadabad				Mumbai				Nagpur				Pune			
ext	fin	gap	CL	North	East	South	West	North	East	South	West	North	East	South	West	North	East	South	West
0	full	0	1	89.94	16.68	10.05	14.78	79.95	13.28	6.82	13.45	71.54	12.14	8.87	20.50	59.45	16.54	7.28	15.21
0	full	0.15	0.3	89.94	75.42	67.73	77.02	80.06	72.04	66.66	75.08	71.54	75.01	66.11	78.32	60.04	77.49	64.94	77.92
0	full	0.15	0.6	89.94	45.22	34.39	45.55	80.06	39.57	31.28	42.80	71.54	42.23	32.26	49.69	60.04	46.71	30.37	46.57
0	full	0.15	1	89.94	21.80	14.36	20.10	80.06	18.14	11.78	18.90	71.54	17.54	13.08	25.30	60.04	22.80	12.02	21.34
0.15	0	0	0.3	100.00	95.07	96.05	96.60	98.91	94.72	96.06	96.68	99.98	95.09	95.64	95.86	95.61	94.79	95.10	96.16
0.15	0	0	0.6	100.00	77.92	76.54	77.37	98.91	77.68	73.50	78.67	99.98	72.56	75.21	81.48	95.61	74.71	72.39	76.29
0.15	0	0	1	100.00	60.73	59.63	57.83	98.91	62.91	55.54	60.92	99.98	52.34	58.48	64.36	95.61	55.76	55.62	56.66
0.15	0	0.15	0.3	100.00	97.36	98.24	98.67	99.44	97.33	98.35	98.74	100.00	97.89	98.15	97.82	97.29	97.34	97.55	98.37
0.15	0	0.15	0.6	100.00	86.15	86.13	85.93	99.44	86.09	83.80	87.06	100.00	82.07	84.98	88.62	97.29	83.93	82.48	85.14
0.15	0	0.15	1	100.00	70.01	68.27	67.25	99.44	72.33	64.80	70.97	100.00	61.33	67.20	73.45	97.29	65.81	64.44	66.84
0.15	1/3	0	0.3	96.37	92.77	92.65	94.58	89.48	91.87	92.59	94.52	89.04	92.39	91.92	94.17	77.99	92.84	91.25	94.45
0.15	1/3	0	0.6	96.37	68.23	62.80	67.67	89.48	65.64	58.64	67.93	89.04	61.99	60.79	73.33	77.99	65.89	57.31	67.44
0.15	1/3	0	1	96.37	44.79	39.77	41.56	89.48	43.41	34.92	42.23	89.04	35.85	38.07	49.53	77.99	40.85	35.09	40.75
0.15	1/3	0.15	0.3	94.35	94.13	93.22	95.81	86.61	93.36	93.24	95.72	83.73	94.07	92.63	95.47	73.02	94.63	91.90	95.97
0.15	1/3	0.15	0.6	94.35	72.66	66.80	72.44	86.61	69.45	63.04	72.21	83.73	67.50	64.70	77.22	73.02	71.76	61.43	72.91
0.15	1/3	0.15	1	94.35	48.13	40.92	44.99	86.61	45.69	36.66	45.50	83.73	38.95	39.11	53.00	73.02	45.52	36.44	45.19
0.15	2/3	0	0.3	91.19	90.48	88.61	92.44	81.70	89.17	88.42	92.36	76.09	89.63	87.42	92.57	63.39	91.00	86.69	92.77
0.15	2/3	0	0.6	91.19	58.85	48.87	58.23	81.70	54.50	43.95	57.86	76.09	52.18	46.21	65.30	63.39	57.81	42.50	59.19
0.15	2/3	0	1	91.19	30.30	21.87	26.89	81.70	26.27	17.15	25.86	76.09	21.74	19.91	35.76	63.39	28.03	17.43	26.95
0.15	2/3	0.15	0.3	90.01	92.05	89.45	93.86	80.62	91.00	89.25	93.79	72.42	91.65	88.37	94.07	61.60	93.03	87.56	94.49
0.15	2/3	0.15	0.6	90.01	64.21	53.97	63.86	80.62	59.76	49.61	63.25	72.42	58.88	51.26	69.95	61.60	64.74	47.94	65.59

Continued

Table III.2(A) Percentage of beam radiation incident on window (0.6m wide by 1.2m height) Continued from previous page

Parameters				Percentage radiation incident (%)															
				Ahmadabad				Mumbai				Nagpur				Pune			
ext	fin	gap	CL	North	East	South	West	North	East	South	West	North	East	South	West	North	East	South	West
0.15	2/3	0.15	1	90.01	35.34	25.50	32.00	80.62	31.05	21.58	31.37	72.42	26.95	23.57	40.73	61.60	34.67	21.43	33.33
0.15	full	0	0.3	89.94	89.08	85.51	91.16	79.95	87.74	85.07	91.16	71.54	88.19	83.79	91.67	59.45	90.03	83.08	91.86
0.15	full	0	0.6	89.94	53.08	39.49	52.29	79.95	48.44	34.77	51.94	71.54	46.89	36.44	60.09	59.45	53.40	33.27	54.34
0.15	full	0	1	89.94	22.11	11.92	18.65	79.95	17.77	7.77	17.59	71.54	15.09	9.74	27.45	59.45	21.82	8.02	19.99
0.15	full	0.15	0.3	89.94	91.31	87.35	93.18	80.47	90.31	87.05	93.19	71.54	90.95	85.83	93.60	61.13	92.56	85.22	94.04
0.15	full	0.15	0.6	89.94	60.96	48.57	60.52	80.47	56.59	44.67	60.09	71.54	56.24	45.53	66.79	61.13	62.44	42.97	62.98
0.15	full	0.15	1	89.94	31.03	20.04	27.75	80.47	26.92	16.64	27.40	71.54	23.92	17.80	36.06	61.13	31.68	16.46	29.96

Radiation on unshaded window (0.6 m wide by 1.2 m height)

	<u>North (Wh/m²-year)</u>	<u>East (Wh/m²-year)</u>	<u>South (Wh/m²-year)</u>	<u>West (Wh/m²-year)</u>
Ahmadabad	4575	369392	599872	456362
Mumbai	4549	184624	381757	290797
Nagpur	5808	287657	547393	534582
Pune	11562	372541	529888	467038

Table III.2(B) Percentage of beam radiation incident on window (0.6m wide by 1.8m height)

Parameters				Percentage radiation incident (%)															
				Ahmadabad				Mumbai				Nagpur				Pune			
ext	fin	gap	CL	North	East	South	West	North	East	South	West	North	East	South	West	North	East	South	West
0	0	0	0.3	99.65	85.77	86.02	86.42	95.87	85.59	85.44	86.76	98.48	84.72	85.77	87.38	88.97	84.78	84.82	85.88
0	0	0	0.6	99.65	73.45	74.12	72.55	95.87	74.25	72.96	74.21	98.48	69.43	73.66	75.68	88.97	71.20	72.53	71.96
0	0	0	1	99.65	63.84	66.03	62.40	95.87	66.43	64.34	65.71	98.48	58.88	65.31	66.15	88.97	60.81	64.35	62.04
0	0	0.15	0.3	100.00	93.56	94.00	94.41	98.03	93.36	93.55	94.70	100.00	93.01	93.74	94.94	93.00	92.80	92.90	93.89
0	0	0.15	0.6	100.00	81.49	82.01	80.69	98.03	82.29	80.93	82.38	100.00	77.43	81.44	83.64	93.00	79.40	80.43	80.22
0	0	0.15	1	100.00	71.29	73.59	70.17	98.03	73.95	71.94	73.50	100.00	66.68	72.84	73.60	93.00	68.33	71.85	69.76
0	1/3	0	0.3	94.48	77.27	74.59	78.31	83.72	75.65	73.61	77.82	84.58	76.04	73.79	79.87	67.86	77.00	72.42	78.08
0	1/3	0	0.6	94.48	56.77	52.90	56.08	83.72	54.85	50.98	56.00	84.58	52.50	52.03	60.08	67.86	55.38	50.32	55.88
0	1/3	0	1	94.48	42.08	40.20	40.86	83.72	41.78	37.88	41.84	84.58	37.39	39.41	44.99	67.86	40.11	37.90	40.55
0	1/3	0.15	0.3	93.48	82.94	79.70	84.25	83.24	80.96	78.75	83.51	82.59	82.12	78.74	85.55	67.46	83.09	77.41	84.14
0	1/3	0.15	0.6	93.48	60.66	55.51	60.13	83.24	58.08	53.50	59.65	82.59	56.31	54.41	64.14	67.46	59.68	52.73	60.18
0	1/3	0.15	1	93.48	44.19	41.50	43.37	83.24	43.26	39.09	43.80	82.59	39.98	40.65	47.23	67.46	42.61	39.05	43.04
0	2/3	0	0.3	89.20	69.04	63.36	70.28	74.68	66.09	61.93	69.01	71.12	67.44	62.00	72.56	52.31	69.52	60.33	70.47
0	2/3	0	0.6	89.20	40.97	32.78	40.45	74.68	36.59	30.16	38.73	71.12	36.56	31.44	45.15	52.31	40.65	29.54	40.75
0	2/3	0	1	89.20	22.28	17.35	21.33	74.68	19.34	14.97	20.13	71.12	18.30	16.53	25.41	52.31	21.65	15.20	21.21
0	2/3	0.15	0.3	88.55	74.99	68.79	76.47	75.53	71.80	67.38	75.02	70.13	73.88	67.27	78.50	54.07	75.92	65.69	76.82
0	2/3	0.15	0.6	88.55	45.76	36.55	45.34	75.53	41.07	34.04	43.42	70.13	41.45	35.05	49.99	54.07	45.98	33.40	46.00
0	2/3	0.15	1	88.55	25.94	20.74	25.40	75.53	22.75	18.47	23.92	70.13	22.71	19.89	29.02	54.07	25.88	18.66	25.41
0	full	0	0.3	88.14	64.53	57.05	65.83	73.21	61.17	55.49	64.24	67.83	63.14	55.30	68.32	49.51	65.62	53.85	66.35
0	full	0	0.6	88.14	33.83	23.94	33.35	73.21	29.03	21.60	31.25	67.83	30.21	22.44	37.94	49.51	34.56	21.12	34.23

Continued

Table III.2(B) Percentage of beam radiation incident on window (0.6m wide by 1.8m height) Continued from previous page

Parameters				Percentage radiation incident (%)															
				Ahmadabad				Mumbai				Nagpur				Pune			
ext	fin	gap	CL	North	East	South	West	North	East	South	West	North	East	South	West	North	East	South	West
0	Full	0	1	88.14	14.35	8.46	13.61	73.21	11.01	6.41	11.98	67.83	11.63	7.52	17.05	49.51	14.99	6.79	14.06
0	Full	0.15	0.3	88.44	72.32	65.03	73.81	75.36	68.94	63.61	72.18	69.35	71.43	63.27	75.88	53.54	73.63	61.94	74.36
0	Full	0.15	0.6	88.44	41.87	31.83	41.49	75.36	37.07	29.58	39.41	69.35	38.22	30.21	45.90	53.54	42.75	29.02	42.49
0	full	0.15	1	88.44	21.80	16.03	21.38	75.36	18.54	14.01	19.78	69.35	19.43	15.05	24.51	53.54	22.52	14.29	21.78
0.15	0	0	0.3	98.49	83.79	83.61	84.66	91.23	83.10	82.87	84.75	95.17	82.70	83.24	85.75	80.56	82.79	82.01	84.07
0.15	0	0	0.6	98.49	68.07	67.15	67.10	91.23	67.77	65.50	68.06	95.17	63.18	66.67	70.81	80.56	65.52	64.84	66.27
0.15	0	0	1	98.49	55.14	55.30	53.66	91.23	56.60	52.82	55.98	95.17	49.10	54.70	57.84	80.56	51.46	52.76	52.62
0.15	0	0.15	0.3	99.78	92.18	92.41	93.23	94.21	91.54	91.86	93.34	98.66	91.58	92.09	93.88	85.85	91.31	90.96	92.62
0.15	0	0.15	0.6	99.78	76.76	75.82	75.90	94.21	76.54	74.29	76.95	98.66	71.73	75.26	79.43	85.85	74.28	73.53	75.15
0.15	0	0.15	1	99.78	63.05	63.50	61.96	94.21	64.65	61.06	64.36	98.66	57.34	62.94	65.76	85.85	59.34	60.86	60.79
0.15	1/3	0	0.3	93.29	81.20	79.41	82.42	80.82	80.01	78.54	82.42	81.36	79.81	78.48	83.89	62.83	80.68	77.21	82.22
0.15	1/3	0	0.6	93.29	57.83	52.37	56.81	80.82	55.37	49.81	56.88	81.36	52.27	50.99	62.01	62.83	56.44	48.85	57.07
0.15	1/3	0	1	93.29	38.71	34.30	37.01	80.82	36.82	31.18	37.01	81.36	32.35	32.97	42.31	62.83	36.35	31.16	36.48
0.15	1/3	0.15	0.3	93.26	88.97	87.16	90.44	81.45	87.72	86.46	90.43	81.49	87.98	86.16	91.57	64.02	88.71	84.99	90.32
0.15	1/3	0.15	0.6	93.26	64.04	57.40	63.13	81.45	61.13	54.76	63.07	81.49	58.22	55.74	68.47	64.02	63.01	53.66	63.73
0.15	1/3	0.15	1	93.26	42.68	37.53	41.32	81.45	40.18	34.37	40.89	81.49	36.67	36.06	46.51	64.02	40.66	34.25	40.85
0.15	2/3	0	0.3	88.35	78.97	75.49	80.36	73.53	77.41	74.45	80.33	69.09	77.18	74.08	82.33	50.21	78.92	72.77	80.60
0.15	2/3	0	0.6	88.35	48.74	38.86	47.66	73.53	44.66	35.60	47.14	69.09	42.86	36.82	54.16	50.21	48.68	34.56	49.10
0.15	2/3	0	1	88.35	24.66	17.03	22.77	73.53	20.37	13.99	21.21	69.09	18.78	15.36	28.89	50.21	24.04	14.11	23.19
0.15	2/3	0.15	0.3	89.42	86.98	83.50	88.59	76.22	85.46	82.60	88.60	71.31	85.70	82.02	90.22	54.80	87.18	80.81	88.91
0.15	2/3	0.15	0.6	89.42	55.94	45.07	54.92	76.22	51.85	41.95	54.50	71.31	50.04	42.86	61.43	54.80	56.29	40.81	56.73

Continued

Table III.2(B) Percentage of beam radiation incident on window (0.6m wide by 1.8m height) Continued from previous page

Parameters				Percentage radiation incident (%)															
				Ahmadabad				Mumbai				Nagpur				Pune			
ext	fin	gap	CL	North	East	South	West	North	East	South	West	North	East	South	West	North	East	South	West
0.15	2/3	0.15	1	89.42	30.43	22.66	28.88	76.22	26.19	19.78	27.39	71.31	25.27	20.99	34.65	54.80	30.28	19.77	29.51
0.15	full	0	0.3	88.14	78.36	73.87	79.80	73.21	76.82	72.76	79.83	67.83	76.59	72.14	81.94	49.51	78.52	70.96	80.23
0.15	Full	0	0.6	88.14	46.11	34.53	44.95	73.21	42.05	31.54	44.55	67.83	40.66	32.23	51.63	49.51	46.78	30.50	46.97
0.15	full	0	1	88.14	21.10	12.59	19.23	73.21	16.87	9.92	17.81	67.83	16.15	10.70	25.08	49.51	21.51	10.03	20.32
0.15	full	0.15	0.3	89.42	86.74	82.68	88.37	76.22	85.27	81.75	88.41	71.31	85.48	80.99	90.06	54.80	87.05	79.92	88.77
0.15	full	0.15	0.6	89.42	54.81	43.20	53.76	76.22	50.82	40.33	53.43	71.31	49.21	40.81	60.25	54.80	55.53	39.18	55.84
0.15	full	0.15	1	89.42	29.01	20.78	27.53	76.22	24.93	18.16	26.19	71.31	24.39	18.94	33.01	54.80	29.38	18.14	28.49

Radiation on unshaded window (0.6 m wide by 1.8 m height)

	<u>North (Wh/m²-year)</u>	<u>East (Wh/m²-year)</u>	<u>South (Wh/m²-year)</u>	<u>West (Wh/m²-year)</u>
Ahmadabad	4668	386015	628425	476830
Mumbai	4968	193468	399947	303775
Nagpur	6125	301676	573212	555261
Pune	13883	390659	556658	489083

Table III.2(C) Percentage of beam radiation incident on window (1.2m wide by 1.8m height)

Parameters				Percentage radiation incident (%)															
				Ahmadabad				Mumbai				Nagpur				Pune			
ext	fin	gap	CL	North	East	South	West	North	East	South	West	North	East	South	West	North	East	South	West
0	0	0	0.3	87.74	83.91	84.00	84.80	80.09	83.18	83.37	84.93	81.70	82.97	83.69	85.91	70.26	82.96	82.45	84.30
0	0	0	0.6	87.74	68.12	67.30	67.19	80.09	67.40	65.67	68.03	81.70	63.37	66.75	71.05	70.22	65.78	64.96	66.66
0	0	0	1	87.74	54.35	54.11	52.82	80.09	54.67	51.36	54.51	81.70	48.54	53.26	57.38	70.22	51.02	51.36	52.15
0	0	0.15	0.3	93.26	92.05	92.46	93.11	84.84	91.36	92.03	93.23	88.31	91.57	92.20	93.79	76.52	91.27	91.07	92.59
0	0	0.15	0.6	93.26	76.49	75.60	75.71	84.84	75.81	74.09	76.59	88.31	71.64	74.96	79.31	76.48	74.26	73.26	75.23
0	0	0.15	1	93.26	61.89	61.85	60.76	84.84	62.33	59.13	62.48	88.31	56.43	61.08	64.96	76.48	58.60	58.97	59.94
0	1/3	0	0.3	64.24	79.31	78.07	80.62	62.84	77.74	77.38	80.51	54.75	78.45	77.44	82.00	47.49	78.74	76.12	80.37
0	1/3	0	0.6	64.24	58.25	54.27	57.79	62.67	56.01	52.31	57.81	54.75	53.19	53.17	62.42	46.85	56.76	50.97	57.67
0	1/3	0	1	64.24	39.63	35.12	38.50	62.67	37.87	31.84	38.85	54.75	33.58	33.80	43.90	46.85	37.47	31.58	38.40
0	1/3	0.15	0.3	64.48	86.33	85.05	87.91	64.15	84.63	84.56	87.73	55.71	85.94	84.39	88.92	49.15	86.04	83.19	87.72
0	1/3	0.15	0.6	64.48	64.25	59.39	64.06	63.94	61.74	57.48	63.95	55.71	59.07	58.05	68.59	48.39	63.13	55.90	64.12
0	1/3	0.15	1	64.48	43.73	38.39	43.11	63.94	41.74	35.07	43.22	55.71	38.07	37.04	48.31	48.39	42.00	34.61	43.04
0	2/3	0	0.3	50.20	75.18	72.44	76.67	53.64	73.00	71.63	76.37	38.37	74.19	71.50	78.39	34.54	75.00	70.18	76.72
0	2/3	0	0.6	50.20	49.79	42.52	49.62	53.42	46.56	40.27	49.04	38.37	44.65	40.87	54.76	33.73	49.25	38.56	49.97
0	2/3	0	1	50.20	27.85	19.51	26.94	53.42	25.08	16.33	26.47	38.37	22.21	17.91	32.74	33.73	27.10	16.00	27.54
0	2/3	0.15	0.3	55.30	82.46	79.68	84.14	57.84	80.22	79.03	83.77	43.91	81.91	78.71	85.50	39.96	82.53	77.51	84.23
0	2/3	0.15	0.6	55.30	56.63	48.62	56.63	57.62	53.30	46.51	56.00	43.91	51.43	46.77	61.55	39.15	56.38	44.67	57.10
0	2/3	0.15	1	55.30	33.53	24.85	33.03	57.62	30.78	21.82	32.51	43.91	28.43	23.24	38.41	39.15	33.08	21.33	33.61
0	full	0	0.3	49.77	73.07	69.50	74.58	53.02	70.69	68.67	74.19	37.05	72.13	68.35	76.36	33.54	73.14	67.18	74.76
0	full	0	0.6	49.77	46.44	38.04	46.35	52.81	43.03	36.00	45.59	37.05	41.61	36.14	51.34	32.73	46.38	34.26	46.86

Continued

Table III.2(C) Percentage beam radiation incident on window (1.2m wide by 1.8m height) Continued from previous page

Parameters				Percentage radiation incident (%)															
				Ahmadabad				Mumbai				Nagpur				Pune			
ext	fin	Gap	CL	North	East	South	West	North	East	South	West	North	East	South	West	North	East	South	West
0	full	0	1	49.77	24.03	14.81	23.24	52.81	21.15	11.96	22.64	37.05	18.96	12.97	28.67	32.73	23.91	11.61	24.09
0	full	0.15	0.3	55.27	81.21	77.97	82.89	57.75	78.88	77.33	82.49	43.67	80.73	76.86	84.24	39.80	81.44	75.79	83.05
0	full	0.15	0.6	55.27	54.81	46.33	54.87	57.53	51.43	44.42	54.16	43.67	49.87	44.35	59.60	38.99	54.86	42.56	55.43
0	full	0.15	1	55.27	31.57	22.55	31.18	57.53	28.81	19.73	30.61	43.67	26.85	20.79	36.24	38.99	31.48	19.22	31.88
0.15	0	0	0.3	81.55	82.79	82.75	83.89	74.24	81.81	82.10	83.92	74.34	81.84	82.39	85.04	62.68	81.87	80.97	83.35
0.15	0	0	0.6	81.55	65.04	63.46	64.18	74.11	63.70	61.67	64.71	74.29	59.76	62.88	68.41	62.25	62.62	60.67	63.58
0.15	0	0	1	81.55	49.03	47.63	47.59	74.11	48.50	44.42	48.78	74.29	42.53	46.78	52.60	62.25	45.47	44.21	46.68
0.15	0	0.15	0.3	87.78	91.21	91.59	92.45	78.91	90.29	91.15	92.50	81.42	90.74	91.31	93.19	68.97	90.41	90.00	91.90
0.15	0	0.15	0.6	87.78	73.69	72.10	72.98	78.78	72.41	70.42	73.58	81.37	68.28	71.42	76.97	68.47	71.34	69.32	72.43
0.15	0	0.15	1	87.78	56.73	55.59	55.70	78.78	56.34	52.39	56.93	81.37	50.60	54.84	60.36	68.47	53.15	52.01	54.62
0.15	1/3	0	0.3	59.40	81.18	80.38	82.62	60.16	79.79	79.80	82.70	50.39	80.37	79.78	83.94	45.02	80.50	78.32	82.34
0.15	1/3	0	0.6	59.40	58.88	54.52	58.37	59.15	56.40	52.49	58.45	49.54	53.20	53.20	63.42	42.09	57.35	50.95	58.39
0.15	1/3	0	1	59.40	38.12	32.36	37.01	59.15	35.78	28.59	37.23	49.54	31.31	30.72	42.93	42.09	35.87	28.02	36.99
0.15	1/3	0.15	0.3	61.23	89.25	88.64	90.89	62.26	87.85	88.30	91.00	52.88	88.94	88.08	91.86	47.81	88.76	86.73	90.67
0.15	1/3	0.15	0.6	61.23	66.13	61.02	65.85	61.18	63.49	59.05	65.92	51.83	60.29	59.45	70.82	44.51	64.90	57.30	66.07
0.15	1/3	0.15	1	61.23	43.43	36.81	42.76	61.18	40.93	32.99	42.86	51.83	36.99	35.10	48.54	44.51	41.53	32.19	42.82
0.15	2/3	0	0.3	49.81	80.04	78.34	81.60	54.03	78.43	77.77	81.76	38.51	79.16	77.54	83.15	36.23	79.59	76.05	81.59
0.15	2/3	0	0.6	49.81	54.16	46.90	53.84	52.90	51.02	44.65	53.65	37.44	48.37	45.00	59.43	32.94	53.47	42.81	54.41
0.15	2/3	0	1	49.81	30.35	20.64	29.28	52.90	27.23	16.98	29.02	37.44	23.85	18.53	35.73	32.94	29.42	16.29	30.13
0.15	2/3	0.15	0.3	56.01	88.30	86.80	89.99	58.60	86.73	86.43	90.20	45.22	87.90	86.02	91.19	42.31	88.01	84.65	90.04
0.15	2/3	0.15	0.6	56.01	62.12	54.30	61.95	57.48	58.98	52.19	61.81	44.14	56.23	52.18	67.35	38.94	61.65	50.21	62.65

Continued

Table III.2(C) Percentage beam radiation incident on window (1.2m wide by 1.8m height) Continued from previous page

Parameters				Percentage radiation incident (%)															
				Ahmadabad				Mumbai				Nagpur				Pune			
ext	fin	gap	CL	North	East	South	West	North	East	South	West	North	East	South	West	North	East	South	West
0.15	2/3	0.15	1	56.01	37.05	27.13	36.36	57.48	34.03	23.64	36.14	44.14	31.08	25.02	42.45	38.94	36.32	22.76	37.19
0.15	full	0	0.3	49.77	79.79	77.58	81.32	53.94	78.14	77.00	81.56	38.12	78.90	76.64	82.96	36.01	79.41	75.21	81.42
0.15	full	0	0.6	49.77	52.94	44.78	52.63	52.81	49.78	42.68	52.44	37.05	47.31	42.62	58.23	32.73	52.57	40.80	53.38
0.15	full	0	1	49.77	28.68	18.27	27.63	52.81	25.60	14.91	27.43	37.05	22.59	15.91	33.90	32.73	28.21	14.19	28.75
0.15	full	0.15	0.3	56.01	88.21	86.42	89.87	58.60	86.63	86.05	90.13	45.22	87.80	85.55	91.11	42.31	87.95	84.24	89.98
0.15	full	0.15	0.6	56.01	61.60	53.41	61.43	57.47	58.49	51.44	61.31	44.14	55.83	51.17	66.78	38.94	61.29	49.44	62.22
0.15	full	0.15	1	56.01	36.39	26.23	35.74	57.47	33.44	22.88	35.58	44.14	30.66	23.97	41.66	38.94	35.90	21.99	36.69

Radiation on unshaded window (1.2 m wide by 1.8 m height)

	<u>North (Wh/m²-year)</u>	<u>East (Wh/m²-year)</u>	<u>South (Wh/m²-year)</u>	<u>West (Wh/m²-year)</u>
Ahmadabad	8267	412960	687407	505548
Mumbai	6886	209569	435137	323395
Nagpur	11214	323366	627902	587495
Pune	21002	415438	612513	518350

Table III.2(D) Percentage of beam radiation on window (1.8m wide by 1.2m height)

Parameters				Percentage radiation incident (%)															
				Ahmadabad				Mumbai				Nagpur				Pune			
ext	fin	gap	CL	North	East	South	West	North	East	South	West	North	East	South	West	North	East	South	West
0	0	0	0.3	79.18	94.01	95.20	95.88	79.97	93.24	95.34	95.84	76.05	94.26	94.75	95.09	71.26	93.78	94.16	95.42
0	0	0	0.6	78.53	74.23	72.64	74.11	77.27	72.39	69.31	74.72	73.21	68.41	71.21	78.76	66.39	71.32	67.70	73.31
0	0	0	1	78.53	52.72	49.41	50.14	77.27	51.53	44.21	51.30	73.21	43.39	47.92	57.84	66.39	48.38	43.95	49.34
0	0	0.15	0.3	85.51	96.52	97.65	98.16	84.72	96.18	97.85	98.11	83.03	97.39	97.50	97.18	77.96	96.56	96.86	97.78
0	0	0.15	0.6	84.84	82.82	82.88	82.82	81.60	81.19	80.55	83.15	79.94	77.99	81.68	86.02	72.66	80.66	78.80	82.12
0	0	0.15	1	84.84	62.28	58.68	60.18	81.60	60.94	54.15	61.63	79.94	52.65	57.25	67.13	72.66	58.24	53.49	59.61
0	1/3	0	0.3	62.58	91.99	92.56	94.16	69.72	90.87	92.83	94.03	59.21	92.22	92.09	93.50	57.50	91.95	91.36	93.79
0	1/3	0	0.6	61.20	68.91	65.22	69.02	65.55	66.21	61.58	69.31	52.92	62.82	63.43	74.24	49.42	66.46	59.63	68.63
0	1/3	0	1	61.20	44.08	37.14	41.60	65.55	41.89	31.53	42.26	52.92	34.53	35.23	50.18	49.42	40.63	31.00	41.44
0	1/3	0.15	0.3	64.06	93.36	93.50	95.39	71.21	92.53	93.84	95.24	60.43	94.18	93.28	94.63	59.41	93.74	92.47	95.19
0	1/3	0.15	0.6	62.66	75.14	72.21	75.46	66.60	72.37	69.49	75.37	53.82	70.06	70.45	79.41	50.80	73.71	67.31	75.38
0	1/3	0.15	1	62.66	50.29	41.68	48.31	66.60	47.66	36.67	49.11	53.82	40.51	39.63	56.39	50.80	47.55	35.69	48.67
0	2/3	0	0.3	53.06	89.13	88.77	91.50	63.18	87.70	89.01	91.30	47.44	89.27	88.15	91.06	47.55	89.46	87.31	91.36
0	2/3	0	0.6	51.67	63.15	57.24	63.46	58.97	59.87	53.35	63.47	41.09	57.10	54.94	69.04	39.36	61.38	51.23	63.57
0	2/3	0	1	51.67	36.08	25.99	33.67	58.97	33.31	20.38	33.99	41.09	26.86	23.59	42.72	39.36	33.70	19.79	34.21
0	2/3	0.15	0.3	58.28	90.67	89.89	92.84	66.91	89.56	90.14	92.61	52.53	91.40	89.50	92.31	52.62	91.40	88.58	92.87
0	2/3	0.15	0.6	56.89	69.93	64.92	70.38	62.31	66.71	61.95	70.03	45.92	64.90	62.68	74.61	44.00	69.13	59.69	70.74
0	2/3	0.15	1	56.89	43.35	32.21	41.41	62.31	40.31	27.39	41.92	45.92	34.01	29.71	49.78	44.00	41.60	26.40	42.39
0	full	0	0.3	51.71	86.75	85.51	89.19	61.83	85.11	85.62	88.97	44.62	86.90	84.69	88.95	45.10	87.42	83.81	89.27
0	full	0	0.6	50.34	59.06	51.64	59.39	57.63	55.53	47.73	59.25	38.27	53.24	48.97	65.08	36.90	57.84	45.64	59.88

Continued

Table III.2(D) Percentage of beam radiation on window (1.8m wide by 1.2m height) Continued from previous page

Parameters				Percentage radiation incident (%)															
				Ahmadabad				Mumbai				Nagpur				Pune			
ext	fin	gap	CL	North	East	South	West	North	East	South	West	North	East	South	West	North	East	South	West
0	full	0	1	50.34	31.15	19.79	28.79	57.63	28.24	14.43	29.00	38.27	22.56	17.00	37.77	36.90	29.57	13.86	29.82
0	full	0.15	0.3	58.05	88.80	87.36	91.01	66.56	87.59	87.54	90.78	51.61	89.64	86.80	90.57	51.81	89.83	85.94	91.24
0	Full	0.15	0.6	56.65	67.04	61.23	67.55	61.93	63.76	58.36	67.13	45.00	62.38	58.73	71.68	43.18	66.72	56.14	68.20
0	full	0.15	1	56.65	40.11	28.41	38.28	61.93	37.08	23.76	38.78	45.00	31.38	25.61	46.40	43.18	38.97	22.81	39.60
0.15	0	0	0.3	73.70	93.55	94.77	95.58	76.45	92.65	94.94	95.49	71.08	93.86	94.29	94.74	66.48	93.34	93.65	95.09
0.15	0	0	0.6	72.47	72.27	70.14	72.18	72.56	69.95	66.50	72.62	66.36	65.99	68.65	77.13	59.60	69.22	64.70	71.33
0.15	0	0	1	72.47	48.63	44.22	46.03	72.56	46.88	38.45	46.87	66.36	38.60	42.73	54.24	59.60	44.13	38.12	45.12
0.15	0	0.15	0.3	80.64	96.22	97.41	97.99	81.78	95.80	97.64	97.92	78.91	97.19	97.24	96.95	73.99	96.28	96.54	97.60
0.15	0	0.15	0.6	79.06	81.39	81.17	81.40	77.00	79.38	78.64	81.60	73.73	76.14	79.94	84.84	66.02	79.13	76.68	80.68
0.15	0	0.15	1	79.06	58.80	54.18	56.69	77.00	56.88	49.13	57.90	73.73	48.40	52.75	64.13	66.02	54.54	48.36	56.04
0.15	1/3	0	0.3	58.66	92.53	93.41	94.86	67.76	91.48	93.67	94.73	56.42	92.97	92.82	94.08	54.47	92.56	92.22	94.48
0.15	1/3	0	0.6	56.76	68.40	64.41	68.52	62.27	65.48	60.47	68.91	47.69	62.04	62.48	74.18	44.57	65.90	58.33	68.20
0.15	1/3	0	1	56.76	41.63	33.80	39.19	62.27	38.93	27.57	39.64	47.69	31.58	31.65	48.31	44.57	38.20	27.02	39.08
0.15	1/3	0.15	0.3	62.14	94.84	95.50	97.01	70.86	94.25	95.83	96.89	60.06	95.95	95.15	96.06	58.55	95.25	94.52	96.78
0.15	1/3	0.15	0.6	59.88	76.13	73.31	76.43	64.47	73.38	70.40	76.61	50.77	70.87	71.43	80.79	47.46	74.68	68.00	76.45
0.15	1/3	0.15	1	59.88	49.49	40.20	47.57	64.47	46.37	34.64	48.30	50.77	39.17	37.85	56.16	47.46	46.70	33.59	48.02
0.15	2/3	0	0.3	52.57	91.70	92.09	94.21	63.56	90.61	92.32	94.06	48.29	92.13	91.29	93.52	47.85	91.97	90.73	93.97
0.15	2/3	0	0.6	50.68	65.13	59.29	65.38	58.06	61.94	55.12	65.85	39.47	58.91	56.85	71.55	37.85	63.28	52.77	65.59
0.15	2/3	0	1	50.68	36.31	25.61	33.91	58.06	33.13	19.41	34.18	39.47	26.61	22.84	43.53	37.85	33.87	18.77	34.55
0.15	2/3	0.15	0.3	59.20	94.13	94.32	96.43	68.50	93.52	94.56	96.30	55.12	95.23	93.75	95.59	54.53	94.75	93.11	96.33
0.15	2/3	0.15	0.6	56.95	73.34	68.81	73.70	62.11	70.43	65.68	73.95	45.83	68.23	66.44	78.49	43.44	72.48	63.12	74.18

Continued

Table III.2(D) Percentage of beam radiation incident on window (1.8m wide by 1.2m height) Continued from previous page

Parameters				Percentage radiation incident (%)															
				Ahmadabad				Mumbai				Nagpur				Pune			
ext	fin	gap	CL	North	East	South	West	North	East	South	West	North	East	South	West	North	East	South	West
0.15	2/3	0.15	1	56.95	45.12	33.58	43.21	62.11	41.71	28.22	43.82	45.83	35.23	30.68	52.11	43.44	43.22	27.10	44.31
0.15	full	0	0.3	52.23	91.24	91.20	93.84	63.15	90.19	91.32	93.70	47.10	91.71	90.15	93.22	46.90	91.67	89.60	93.71
0.15	full	0	0.6	50.34	63.31	56.27	63.54	57.63	60.16	52.10	64.11	38.27	57.34	53.42	69.94	36.90	61.91	49.67	64.10
0.15	full	0	1	50.34	33.73	21.97	31.34	57.63	30.55	16.06	31.68	38.27	24.57	18.79	40.92	36.90	31.95	15.36	32.45
0.15	full	0.15	0.3	59.18	93.89	93.75	96.25	68.47	93.32	93.92	96.13	54.92	95.03	92.97	95.42	54.41	94.61	92.40	96.21
0.15	full	0.15	0.6	56.93	72.32	67.15	72.67	62.07	69.50	64.13	73.03	45.63	67.45	64.50	77.51	43.32	71.77	61.53	73.40
0.15	full	0.15	1	56.93	43.78	31.79	41.90	62.07	40.47	26.62	42.64	45.63	34.32	28.60	50.65	43.32	42.30	25.47	43.31

Radiation on unshaded window (1.8 m wide by 1.2 m height)

	<u>North (Wh/m²-year)</u>	<u>East (Wh/m²-year)</u>	<u>South (Wh/m²-year)</u>	<u>West (Wh/m²-year)</u>
Ahmadabad	8174	403527	672479	493711
Mumbai	6311	203988	427617	315284
Nagpur	10857	313416	616668	575200
Pune	18625	402145	599192	501918

Table III.2(E) Percentage of beam radiation incident on window (1.8m wide by 1.8m height)

Parameters				Percentage radiation incident (%)															
				Ahmadabad				Mumbai				Nagpur				Pune			
ext	fin	gap	CL	North	East	South	West	North	East	South	West	North	East	South	West	North	East	South	West
0	0	0	0.3	72.95	83.09	83.16	84.20	70.48	82.05	82.63	84.22	67.99	82.18	82.85	85.32	60.22	82.11	81.47	83.62
0	0	0	0.6	72.48	65.71	64.21	64.99	68.65	64.24	62.71	65.45	66.20	60.44	63.70	69.07	57.29	63.36	61.62	64.41
0	0	0	1	72.48	49.52	47.82	48.30	68.65	48.45	44.82	49.21	66.20	43.05	46.94	53.22	57.29	46.12	44.45	47.41
0	0	0.15	0.3	79.27	91.30	91.77	92.57	75.00	90.32	91.42	92.61	74.71	90.89	91.52	93.31	66.37	90.50	90.24	92.03
0	0	0.15	0.6	78.79	74.09	72.58	73.57	73.11	72.64	71.18	74.10	72.90	68.73	71.95	77.38	63.12	71.85	69.99	73.05
0	0	0.15	1	78.79	56.93	55.46	56.14	73.11	55.92	52.45	57.04	72.90	50.82	54.66	60.70	63.12	53.56	51.92	55.12
0	1/3	0	0.3	52.96	79.92	79.15	81.42	58.33	78.47	78.68	81.35	48.41	79.12	78.68	82.72	44.59	79.34	77.17	81.06
0	1/3	0	0.6	51.09	59.00	55.35	58.64	53.88	56.66	53.56	58.78	42.54	53.64	54.33	63.22	37.33	57.40	52.09	58.63
0	1/3	0	1	51.09	39.28	34.01	38.38	53.88	37.10	30.60	38.77	42.54	32.81	32.54	44.06	37.33	37.06	29.94	38.30
0	1/3	0.15	0.3	55.90	87.38	86.78	89.11	60.69	85.90	86.50	89.05	51.46	87.08	86.32	90.06	47.89	87.07	84.91	88.85
0	1/3	0.15	0.6	54.03	65.83	61.58	65.73	56.11	63.32	59.84	65.85	45.31	60.38	60.33	70.14	40.11	64.51	58.21	65.92
0	1/3	0.15	1	54.03	44.42	38.47	43.99	56.11	42.10	34.98	44.27	45.31	38.35	36.95	49.47	40.11	42.51	34.12	43.96
0	2/3	0	0.3	44.59	77.13	75.45	78.83	52.69	75.38	74.95	78.69	38.43	76.28	74.82	80.32	36.70	76.92	73.24	78.70
0	2/3	0	0.6	42.70	53.40	47.60	53.23	48.16	50.51	45.57	53.09	32.29	48.10	46.09	58.12	29.21	52.48	43.96	53.71
0	2/3	0	1	42.70	31.50	23.23	30.68	48.16	28.78	19.81	30.73	32.29	25.37	21.28	36.76	29.21	30.33	19.12	31.28
0	2/3	0.15	0.3	50.65	84.76	83.26	86.63	56.89	83.02	82.91	86.51	44.51	84.40	82.65	87.78	42.32	84.81	81.16	86.60
0	2/3	0.15	0.6	48.77	60.77	54.55	60.80	52.30	57.83	52.61	60.68	38.36	55.42	52.84	65.44	34.52	60.08	50.92	61.43
0	2/3	0.15	1	48.77	37.67	29.32	37.28	52.30	34.98	25.96	37.29	38.36	32.06	27.34	43.00	34.52	36.74	25.11	37.86
0	full	0	0.3	44.32	75.68	73.53	77.43	52.36	73.88	72.99	77.29	37.65	74.93	72.78	78.96	36.06	75.72	71.25	77.46
0	full	0	0.6	42.44	51.15	44.71	51.02	47.83	48.21	42.74	50.84	31.52	46.12	43.00	55.83	28.57	50.60	41.17	51.74

Continued

Table III.2(E) Percentage of beam radiation incident on window (1.8m wide by 1.8m height) Continued from previous page

Parameters				Percentage radiation incident (%)															
				Ahmadabad				Mumbai				Nagpur				Pune			
ext	fin	gap	CL	North	East	South	West	North	East	South	West	North	East	South	West	North	East	South	West
0	full	0	1	50.34	31.15	19.79	28.79	57.63	28.24	14.43	29.00	38.27	22.56	17.00	37.77	36.90	29.57	13.86	29.82
0	full	0.15	0.3	58.05	88.80	87.36	91.01	66.56	87.59	87.54	90.78	51.61	89.64	86.80	90.57	51.81	89.83	85.94	91.24
0	full	0.15	0.6	56.65	67.04	61.23	67.55	61.93	63.76	58.36	67.13	45.00	62.38	58.73	71.68	43.18	66.72	56.14	68.20
0	full	0.15	1	56.65	40.11	28.41	38.28	61.93	37.08	23.76	38.78	45.00	31.38	25.61	46.40	43.18	38.97	22.81	39.60
0.15	0	0	0.3	73.70	93.55	94.77	95.58	76.45	92.65	94.94	95.49	71.08	93.86	94.29	94.74	66.48	93.34	93.65	95.09
0.15	0	0	0.6	72.47	72.27	70.14	72.18	72.56	69.95	66.50	72.62	66.36	65.99	68.65	77.13	59.60	69.22	64.70	71.33
0.15	0	0	1	72.47	48.63	44.22	46.03	72.56	46.88	38.45	46.87	66.36	38.60	42.73	54.24	59.60	44.13	38.12	45.12
0.15	0	0.15	0.3	80.64	96.22	97.41	97.99	81.78	95.80	97.64	97.92	78.91	97.19	97.24	96.95	73.99	96.28	96.54	97.60
0.15	0	0.15	0.6	79.06	81.39	81.17	81.40	77.00	79.38	78.64	81.60	73.73	76.14	79.94	84.84	66.02	79.13	76.68	80.68
0.15	0	0.15	1	79.06	58.80	54.18	56.69	77.00	56.88	49.13	57.90	73.73	48.40	52.75	64.13	66.02	54.54	48.36	56.04
0.15	1/3	0	0.3	58.66	92.53	93.41	94.86	67.76	91.48	93.67	94.73	56.42	92.97	92.82	94.08	54.47	92.56	92.22	94.48
0.15	1/3	0	0.6	56.76	68.40	64.41	68.52	62.27	65.48	60.47	68.91	47.69	62.04	62.48	74.18	44.57	65.90	58.33	68.20
0.15	1/3	0	1	56.76	41.63	33.80	39.19	62.27	38.93	27.57	39.64	47.69	31.58	31.65	48.31	44.57	38.20	27.02	39.08
0.15	1/3	0.15	0.3	62.14	94.84	95.50	97.01	70.86	94.25	95.83	96.89	60.06	95.95	95.15	96.06	58.55	95.25	94.52	96.78
0.15	1/3	0.15	0.6	59.88	76.13	73.31	76.43	64.47	73.38	70.40	76.61	50.77	70.87	71.43	80.79	47.46	74.68	68.00	76.45
0.15	1/3	0.15	1	59.88	49.49	40.20	47.57	64.47	46.37	34.64	48.30	50.77	39.17	37.85	56.16	47.46	46.70	33.59	48.02
0.15	2/3	0	0.3	52.57	91.70	92.09	94.21	63.56	90.61	92.32	94.06	48.29	92.13	91.29	93.52	47.85	91.97	90.73	93.97
0.15	2/3	0	0.6	50.68	65.13	59.29	65.38	58.06	61.94	55.12	65.85	39.47	58.91	56.85	71.55	37.85	63.28	52.77	65.59
0.15	2/3	0	1	50.68	36.31	25.61	33.91	58.06	33.13	19.41	34.18	39.47	26.61	22.84	43.53	37.85	33.87	18.77	34.55
0.15	2/3	0.15	0.3	59.20	94.13	94.32	96.43	68.50	93.52	94.56	96.30	55.12	95.23	93.75	95.59	54.53	94.75	93.11	96.33
0.15	2/3	0.15	0.6	56.95	73.34	68.81	73.70	62.11	70.43	65.68	73.95	45.83	68.23	66.44	78.49	43.44	72.48	63.12	74.18

Continued

Table III.2(E) Percentage of beam radiation incident on window (1.8m wide by 1.8m height) Continued from previous page

Parameters				Percentage radiation incident (%)															
				Ahmadabad				Mumbai				Nagpur				Pune			
ext	fin	gap	CL	North	East	South	West	North	East	South	West	North	East	South	West	North	East	South	West
0.15	2/3	0.15	1	48.83	39.89	31.36	39.54	52.11	36.87	27.65	39.60	38.21	33.88	29.08	45.69	34.33	38.76	26.65	40.16
0.15	Full	0	0.3	45.32	80.11	78.99	81.96	53.79	78.77	78.37	81.89	40.07	79.48	78.03	83.31	37.73	79.81	76.69	81.73
0.15	Full	0	0.6	42.44	55.41	49.25	55.13	47.83	52.79	47.20	55.55	31.52	50.09	47.45	60.61	28.57	54.61	45.37	55.88
0.15	full	0	1	42.44	31.95	23.05	31.18	47.83	28.99	19.41	31.35	31.52	25.80	20.51	37.59	28.57	31.02	18.61	32.12
0.15	full	0.15	0.3	51.82	88.52	87.84	90.51	58.18	87.23	87.43	90.45	46.98	88.37	86.97	91.47	43.91	88.34	85.72	90.29
0.15	full	0.15	0.6	48.83	63.98	57.83	63.91	52.11	61.35	55.90	64.38	38.21	58.52	55.93	69.11	34.33	63.23	53.96	64.68
0.15	full	0.15	1	48.83	39.45	30.79	39.13	52.11	36.50	27.16	39.25	38.21	33.62	28.39	45.17	34.33	38.49	26.15	39.86

Radiation on unshaded window (1.8 m wide by 1.8 m height)

	<u>North (Wh/m²-year)</u>	<u>East (Wh/m²-year)</u>	<u>South (Wh/m²-year)</u>	<u>West (Wh/m²-year)</u>
Ahmadabad	9694	423229	706689	517515
Mumbai	7603	214886	448880	330390
Nagpur	13182	329996	647446	598446
Pune	24055	423475	631509	527060

Table III.3 Best combinations of windows and shading devices and corresponding beam radiation incident on window

Orientation	Combination					Radiation on window (kWh/year)			
	Size (w X h)	Ext (m)	Gap (m)	CL (m)	fin-ht	Ahmadabad	Mumbai	Nagpur	Pune
North	0.6X1.2	0.0	0.0	0.3	full	3(3)	3(3)	3(4)	5(8)
	0.6X1.8	0.0	0.0	0.3	full	4 (5)	4(5)	4(7)	7(15)
	1.2X1.2	0.0	0.0	*	full	6(10)	5(8)	6(14)	10(24)
	1.2X1.8	0.0	0.0	*	full	9(18)	8(15)	9(24)	15(45)
	1.8X1.2	0.0	0.0	0.6	full	9(18)	8(14)	9(23)	15(40)
	1.8X1.8	0.0	0.0	0.6	full	13(31)	12(25)	13(43)	22(78)
East	0.6X1.2	0.0	0.0	1.0	full	44(266)	18(133)	25(207)	44(268)
	0.6X1.8	0.0	0.0	1.0	full	60(417)	23(209)	38(326)	63(422)
	1.2X1.2	0.0	0.0	1.0	full	149(567)	67(287)	83(443)	144(569)
	1.2X1.8	0.0	0.0	1.0	full	214(892)	96(453)	132(698)	215(897)
	1.8X1.2	0.0	0.0	1.0	full	272(872)	124(441)	153(677)	257(869)
	1.8X1.8	0.0	0.0	1.0	full	397(1371)	183(696)	249(1069)	388(1372)
South	0.6X1.2	0.0	0.0	1.0	full	43(432)	19(275)	35(394)	28(382)
	0.6X1.8	0.0	0.0	1.0	full	57(679)	28(432)	47(619)	41(601)
	1.2X1.2	0.0	0.0	1.0	full	139(943)	61(597)	107(862)	84(838)
	1.2X1.8	0.0	0.0	1.0	full	220(1485)	112(940)	176(1356)	154(1323)
	1.8X1.2	0.0	0.0	1.0	full	287(1453)	133(924)	226(1332)	179(1294)
	1.8X1.8	0.0	0.0	1.0	full	463(2290)	246(1454)	378(2098)	333(2046)
West	0.6X1.2	0.0	0.0	1.0	full	49(329)	28(209)	79(385)	51(336)
	0.6X1.8	0.0	0.0	1.0	full	70(515)	39(328)	102(600)	74(528)
	1.2X1.2	0.0	0.0	1.0	full	166(695)	105(445)	263(813)	178(711)
	1.2X1.8	0.0	0.0	1.0	full	254(1092)	158(699)	364(1269)	270(1120)
	1.8X1.2	0.0	0.0	1.0	full	307(1066)	197(681)	469(1242)	323(1084)
	1.8X1.8	0.0	0.0	1.0	full	473 (1677)	302 (1070)	661 (1939)	496 (1708)

* 0.3 for Mumbai and Pune; 0.6 for Ahmadabad and Nagpur

w : Width in meters h :Height in meters

The numbers in parentheses show the corresponding radiation values on an unshaded window.

APPENDIX III.2

TYPES OF INSULATION

The building envelope is a device through which heat exchange between the internal and external environments is controlled. The various modes of operation of an envelope are: (1) admit heat gain, (2) exclude heat gain, (3) containing heat gain, or (4) dissipating excess internal heat. The opaque portions of the envelope, once designed, are generally considered fixed controls. The dynamic elements of the envelope include openable windows, shading devices and insulating shutters.

The effect of insulation is to reduce heat gain and heat loss. The more insulation in a buildings exterior envelope, the less heat transferred into or out of the building due to temperature difference between the interior and exterior. Insulation also controls the interior mean radiant temperature (MRT) by isolating the interior surfaces from the influence of the exterior conditions, and also reduces drafts produced by temperature differences between walls and air.



Insulation along with infiltration control is important for reducing heating and cooling loads in skin-load-dominated buildings such as residences (internal load dominated buildings are typically offices). Increased insulation levels in internally load-dominated buildings, may cause an increase in energy usage for cooling when the outside is cooler than the inside, unless natural ventilation or an economiser cycle on the HVAC system is available.

Types:

Insulation is made from a variety of materials and in several forms. The forms generally fall into the following categories: (1) rigid or semirigid blocks or boards, (2) boards with impact- or weather-resistant surfaces, which are employed on building exteriors or below grade, (3) blankets, felts, or sheets, which are either mechanically attached to vertical surfaces or laid flat on horizontal ones, (4) loose-fill, which is poured or blown into cavities or onto flat surfaces such as above ceilings, (5) foams and dry spray-on types; which can be pneumatically applied in a variety of ways. When specifying insulation, both performance and any complications arising from the thickness required must be considered.



Rigid

In the first category are polystyrene, polyurethane (PUF), and polyisocyanurate. Polystyrene comes in the form of “beadboard” so called because it is manufactured from small Styrofoam beads which are puffed up and fused together into slabs (also called as thermocole) – and extruded polystyrene. The latter has the advantage of some compressive strength, which makes it suitable for insulating beneath heavy objects. High-density beadboard also has a high compressive strength (generally found as packing material in the cartons for electrical appliances such as televisions and refrigerators).

Both burn readily and give off a dense black smoke. Polyurethane (PUF) and polyisocyanurate are harder to ignite but give off cyanide fumes in a fire. In case of fire, these are hazardous, hence they are generally not exposed on interior surfaces but covered with a fireproof wall or plaster or sheetrock.

The most common way of insulating masonry walls is to affix rigid sheets of insulation to the wall surfaces, and covering them with a protective material. For a given thickness, the most effective insulation material is polyurethane foam. 25 mm of urethane is equivalent to about 50 mm of fibreglass. The rigid sheets are available in 12mm to 50 mm thickness.



Blanket

This type of insulation is most commonly used in standard cavity walls, where the depth of the stud determines the amount of insulation that can be placed in the wall. The material usually consists of glass fibre or mineral wool. It is manufactured in standard widths of 400mm - 600mm and is generally 75 to 175 mm thick. It comes in long rolls or batts of specific length. It is available with reflective foil or a vapour barrier on one side. One advantage of fibreglass is that it is highly fire resistant. Its drawbacks are that it loses its effectiveness when wet, and that it is not self-supporting in its normal form.

Loose fill

Loose fill insulations that are commercially available include cellulose, vermiculite, and blown in fibreglass. Sawdust, wood shavings, and shredded bark can also be used. These materials are principally used in existing walls that were not insulated during construction. They are also commonly added between ceiling joists in unheated attics. Vermiculite and perlite are mixed with concrete aggregates to reduce heat loss.



Foam-in-situ

Foams such as polyurethane are also available in liquid form with a catalyst for on-the-job foaming. The liquid may be poured into forms or sprayed on with special equipment. In the hands of a skilled applicator, this material can be rendered into almost any sculptural form and will provide considerable structural support. It is applicable to odd-shaped structures, but needs a weather-protective membrane.

Superinsulation

Superinsulation is the application of abnormal amounts of insulation in order to eliminate all need for mechanical space heating. Due to reduction in heat gains and losses due to conduction and air tightness of buildings, the internal and solar heat gains become the primary source of heat. The savings on heating equipment and distribution systems may equal or outweigh the additional costs of extra insulation, extra thermal mass, and insulative window treatments. Since insulation is required at all external surfaces, it can add significantly to the construction cost. Therefore, the desirable amount of insulation must be carefully considered. It is also important to consider overheating in mild winters and summer. The building must be ventilated during such periods. Fresh air due to ventilation also reduces risk of diseases and foul odours

4thFloor 4B, Mandira Apartments,

North Boag Road, T-Nagar Chennai- 600 017

Email: Solarbazaarpl@gmail.com

Web: www.almipl.com

Mobile: 94452 30332 / 9383132332

Green Energy Promoters



APPENDIX III.3

TYPES OF GLAZINGS

Material		Thermal Expansion	Ease of Handling	Weatherability	Estimated Lifetime (years)	Solar Transmissivity (-)	Infrared Transmissivity (-)
Glass	Single Glazed Float Glass	0.47	P	E	25+	0.91	0.01
	Double Glazed Float Glass	0.47	P	E	25+	0.77-0.85	
Acrylic	Flexiglas (Rhom& Haas)	4.10	E	E	10-20	0.90	0.02
	Lucite (Du Pont)	3.90	E	E	10-20	0.92	0.02
	Exolite (CY/RO)	4.00	E	E	10-20	0.83	0.02
Polycarbonate	Lexan (G.E.)	3.75	E	F	15-17	0.81-0.89	0.02
	Tuffack Twinwall (Rhom & Haas)	3.30	E	F	5-7	0.77	
	Cyrolon SDP (CY/RO)	4.00	E	F		0.74	
Fibreglass reinforced polyester	Lascolite (Lasco Industries)	1.60	VG	G	10-20	0.86	
	Filon w/Tedlar (Vistron Corp.)	2.30	VG	G	10-20	0.86	
	Sunlite Premium II (Kalwall)	1.36	E	G	20	0.87	0.02
Polyester film	Mylar Type W (Du Pont)	1.50	F	F	4	0.85	0.16-0.32
	Flexiguard (3M)		F	G	10	0.89	0.095
Polyethylene film	Monsanto 602 (Monsanto)		F	P	1	0.85	0.70
	Teflon (Du Pont)	30.00	P	E	25	0.96	0.57
Polyvinyl fluoride film	Tedlar (Du Pont)	2.80	F	E	10-20	0.95	0.30

P=Poor, F=Fair, G=Good, VG=Very good, E=Excellent